



DOOR CONTROL

Cerniere idrauliche e chiudiporta

Hydraulic hinges and floor springs
Bisagras hidráulicas y cierrapuertas





Indice

Index | Índice

Cerniere idrauliche chiudiporta

Hydraulic hinges
Bisagras hidráulicas

8

9

14

19

23

24

26

28

30

31

32

33

34

36

38

39

Frenum

4FRXN

4FWXN

4FXXN-4FTXN

Latus

4LCXS

4LLXS

4LVXS

Latus80

4L8XS

Latus60

4CLXA

4CLXB

4CVXS

Algor

4A0XR

M25

42

M60

44

KS3000

46

M68

48

M68Z

50

SM68

52

M77

54

Teste di perno

Spindle heads
Pernios intercambiables

56

Accessori

Accessories
Accesorios

58

Chiudiporta a pavimento e aerei

Floor springs and door closers
Cierrapuertas de suelo y RTS

Finiture

Finishes | Acabados

Alluminio | Aluminum | Aluminio



Ottone | Brass

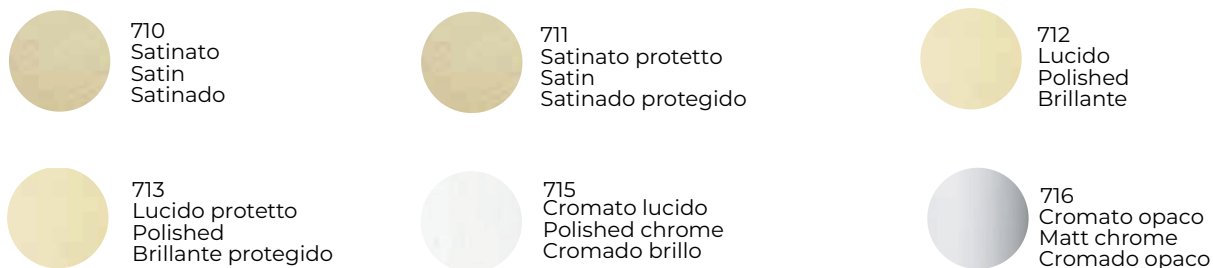

Acciaio inox | Stainless steel

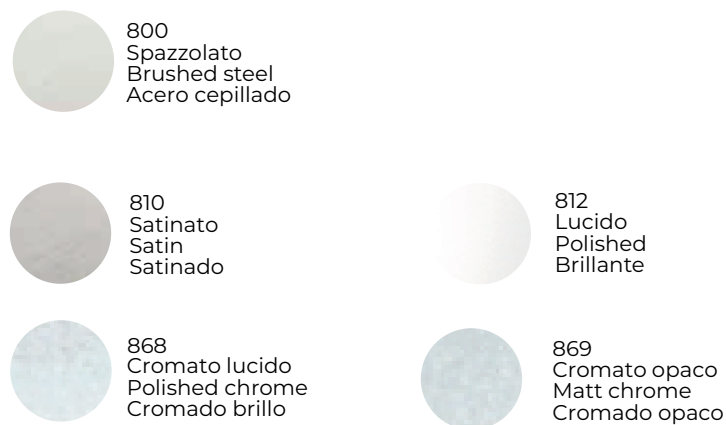

Su richiesta | Upon request | Bajo pedido



Scopri la nostra gamma di colori disponibili su richiesta.
Discover our range of colors available upon request.
Descubre nuestra gama de colores disponible a pedido.

Finiture: grado di resistenza alla corrosione

Finishes: degree of corrosion resistance

Acabados: grado de resistencia a la corrosión

Materiale Material	Finiture Finishes	Interno Internal		Esterno External	
		Porte Doors	Box doccia Showers	Condizioni standard Standard environments	Condizioni particolari Special environments
AL ALU	610	4	4	4	1
AL ALU	611	4	4	4	4
AL ALU	613	4	2	2	1
AL ALU	614	4	2	2	1
AL ALU	615	4	2	2	4
AL ALU	620	4	4	4	1
AL ALU	665	4	3	3	
AL ALU	666	4	3	3	
OT BRASS	710	5	5*	5*	5*
OT BRASS	712	5	5*	5*	5*
OT BRASS	715	5	5*	5*	5*
OT BRASS	716	5	5*	5*	5*
INOX	810	5	5*	5*	5*
INOX	812	5	5*	5*	5*
INOX	868	5	5	5	5
INOX	869	5	5	5	5

*ATTENZIONE: Per installazioni in condizioni ambientali e climatiche particolari (es. umide, acide e saline) è necessaria la zaponatura, finitura ottenuta su ottone grezzo che ha lo scopo di proteggere il materiale dalla naturale ossidazione se non soggetto a pulizia costante in caso di esposizione a condizioni sfavorevoli.

CAUTION: For installations in particular environments or climate (ex. wet, acid, saline) you need to use a varnish brass (a finishes that protect brass from its natural oxidation in case of exposure to unfavorable environmental conditions).

ATENCIÓN: Para Instalaciones en condiciones ambientales particulares (ej. húmedas, ácidas y salinas) es necesario el tratamiento con pintura para latón (un acabado que protege el latón contra su natural oxidación en caso de exposición en condiciones desfavorables).

LEGENDA LEGEND				
1	2	3	4	5
Bassa resistenza alla corrosione Low corrosion resistance	Moderata resistenza alla corrosione Moderate corrosion resistance	Alta resistenza alla corrosione High corrosion resistance	Resistenza molto alta alla corrosione Very high corrosion resistance	Resistenza eccellente alla corrosione Excellent corrosion resistance

Legenda | Legend | Leyenda



Opzionale | dettagli tecnici che influiscono sulla funzionalità
Optional | Technical details that affect the functionality
Opcional | indicaciones técnicas que afectan el funcionamiento



Larghezza anta
Max. door width
Max. ancho de la puerta



Spessore vetro
Glass thickness
Espesor del vidrio



Portata
Weight
Peso



Testato a 500000 cicli come previsto da EN 1527
Tested at 500000 cycles as required by the UNI EN 1527
Testado a 500 000 ciclos como UNI EN 1527



Indicato per docce e saune
Suitable for showers and saunas
Indicado para duchas y saunas



Temperatura tollerabile
Temperature
Temperatura

PROGETTIAMO
DESIGN | DISEÑAMOS

Soluzioni innovative per sistemi in vetro, intelaiati e legno.

Innovative solutions for glass, framed and wooden systems.
Soluciones innovadoras para sistemas en vidrio, madera y con marco



Porte esterne
External doors
Puertas exteriores

ODM

Produciamo accessori su incarico delle industrie.

We produce accessories upon industries request.
Producimos accesorios a petición de la industria.



Partizioni
Glass partitions
Particiones



Controllo porte
Floor springs
Cierra puertas



Porte interne
Internal doors
Puertas interiores



Sistemi scorrevoli
Sliding systems
Sistemas deslizantes



Sistemi doccia
Showers
Duchas

PRODUCIAMO
MANUFACTURE | PRODUCIMOS

Più di 3800 accessori per sistemi in vetro.

More than 3800 accessories for all-glass tempered installations.
Más de 3800 accesorios para instalaciones de vidrio templado.

OEM

Mettiamo a disposizione il nostro know-how per la realizzazione di progetti su misura.

We provide our know-how for customised projects.
Ofrecemos nuestro know-how para proyectos a medida.

COMMERCIALIZZIAMO
COMMERCIALIZE | COMERCIALIZAMOS

In più di 48 paesi grazie ad un fitto network distributivo.

In more than 48 countries with our distributive network.
En más de 48 países con nuestra red de distribución.

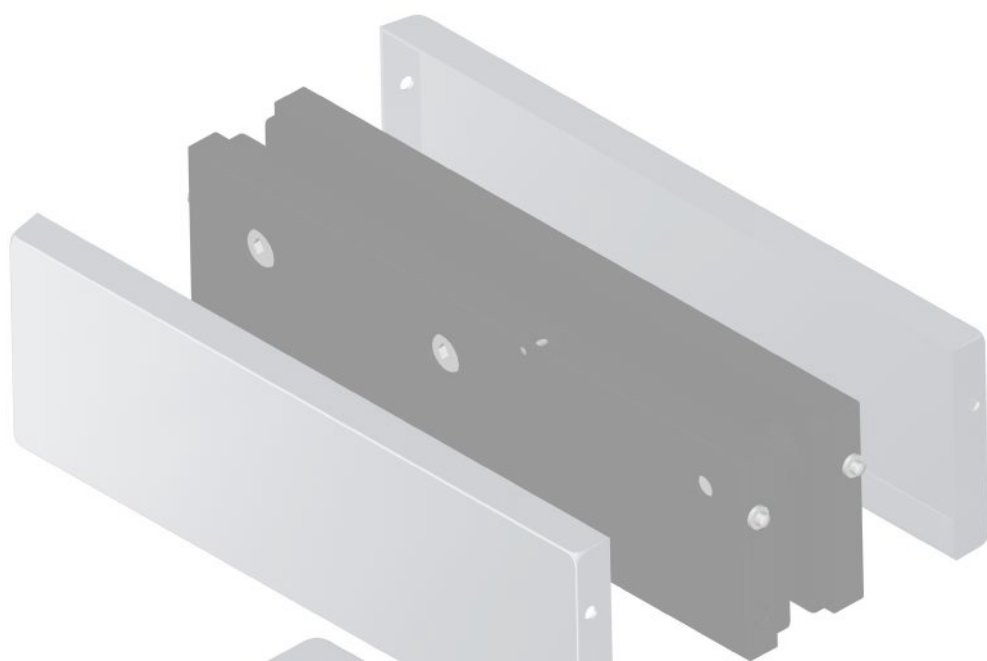

Cerniere idrauliche

Hydraulic hinges | Bisagras hidráulicas

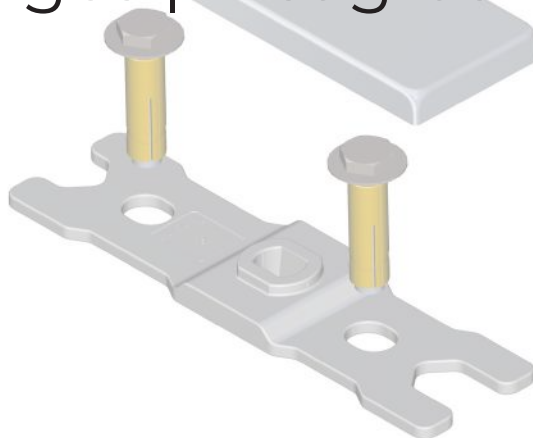





Larghezza max dell'anta
Max door width
Ancho de la puerta
1000 mm
39-3/8"

Spessore vetro
Glass thickness
Espesor del vidrio
8 ÷ 14 mm
5/16 ÷ 9/16"

Peso max
Door weight
Peso máximo
100 kg
220 Lbs

Testata
Tested
Testado
500.000 cicli
cycle - ciclos

KIT

4FRXK KIT Cerniera idraulica
KIT Hydraulic hinge
KIT Bisagra hidráulica

4FRXN
Cerniera idraulica
Hydraulic hinge
Bisagra hidráulica

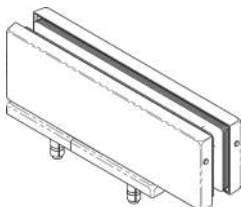

42800
Cerniera libera
Dummy hinge
Bisagra libre

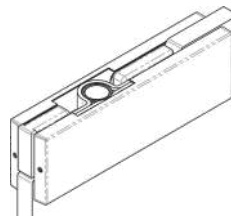

4FR9N
Piastrina a pavimento
Plate
Plaqueta



10180
Perno di rotazione
Pivot
Rotación

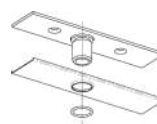

KIT

10180
Perno di rotazione
Pivot
Rotación

42800
Cerniera libera
Dummy hinge
Bisagra libre



4FR9N
Piastrina a pavimento
Plate
Plaqueta

4FRXN
Cerniera idraulica
chiudiporta
Hydraulic hinge
Bisagra hidráulica

Finiture Finishing Acabados



Inclusa con 4FRXN e 4FWXN
Included with 4FRXN and 4FWXN
Incluido con 4FRXN y 4FWXN

Cod. 4FRXN

Applicazione per vetro in angolo
Corner glass application
Aplicación en esquina por vidrio



- Possibile posizione della porta
Possible door position
Posible posición de la puerta
- Chiusura controllata
Self-closing
Cierre controlado
- Posizione libera
Free standing
Posición libre
- Stop

Range di regolazione della posizione
Position adjustment range
Rango de regulación de la posición

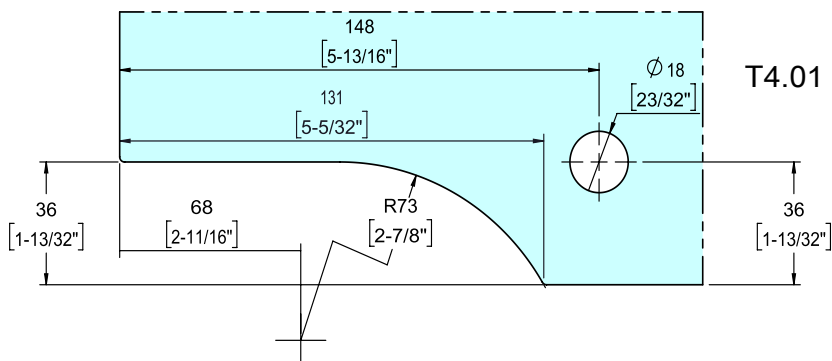
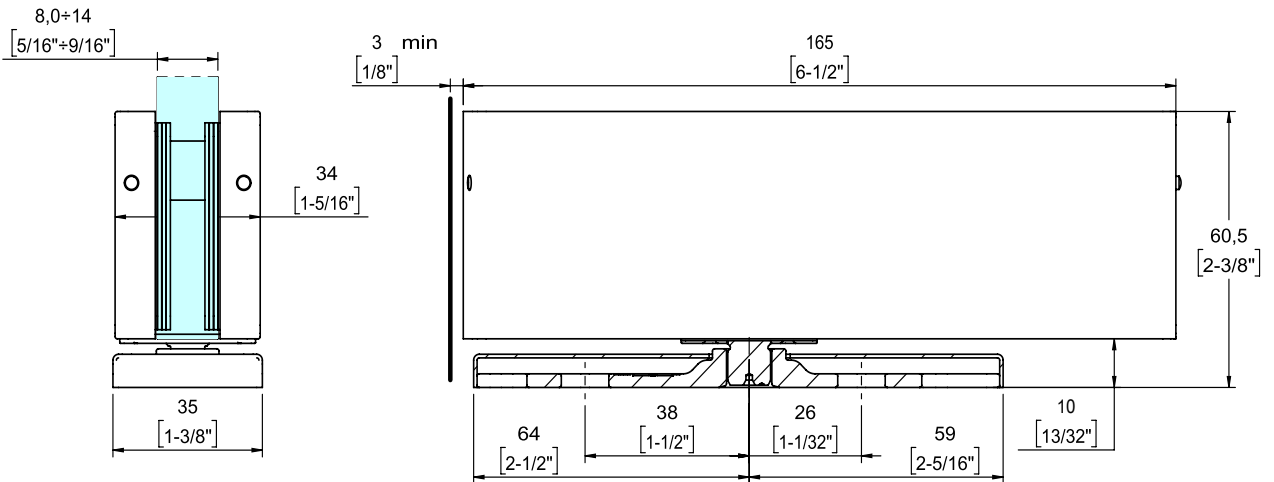
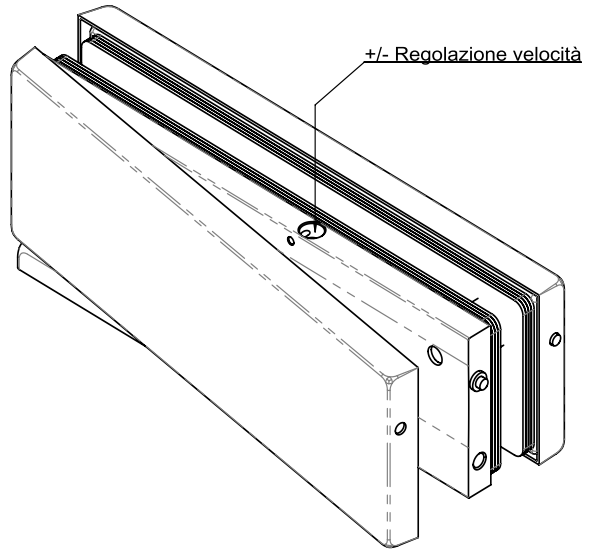
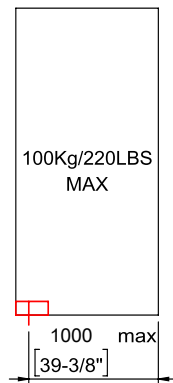
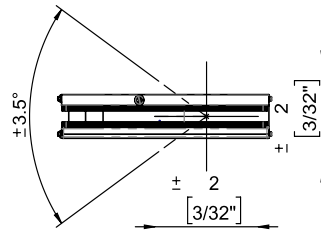
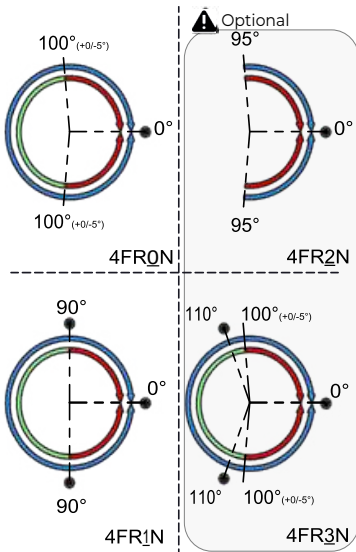

Applicazione per vetro in angolo
Corner glass application
Aplicación en esquina por vidrio

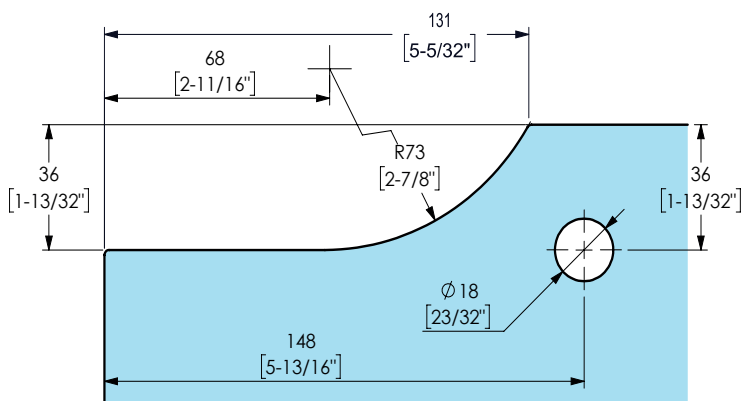
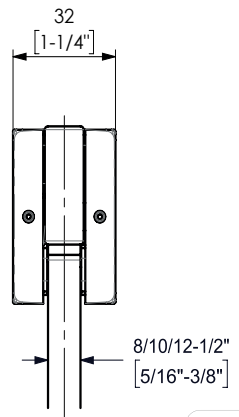
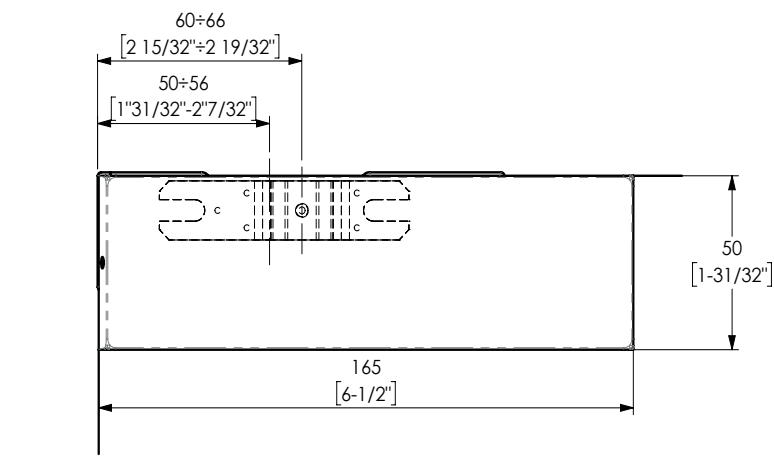
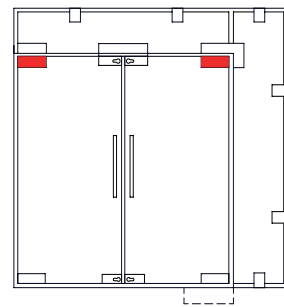
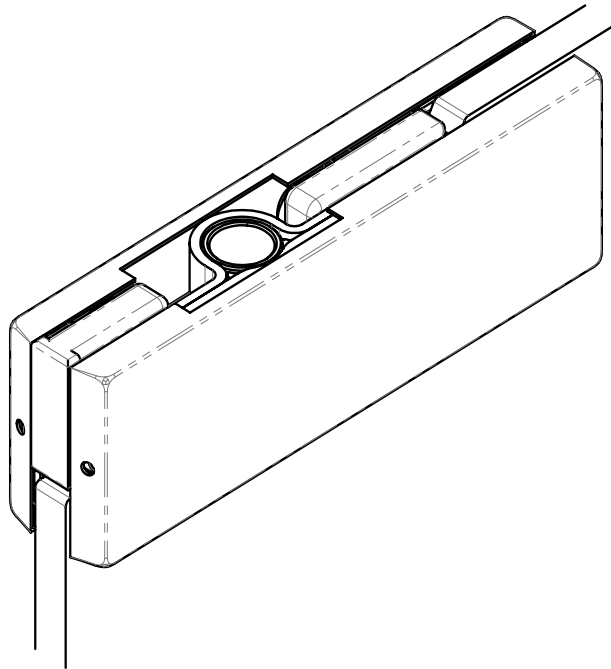

T4.01

Finiture Finishing Acabados	
610	710
611	712
613	810
614	812
620	

Cod. 4FR9N

! Inclusa con 4FRXN e 4FWXN
Included with 4FRXN and 4FWXN
Incluido con 4FRXN y 4FWXN

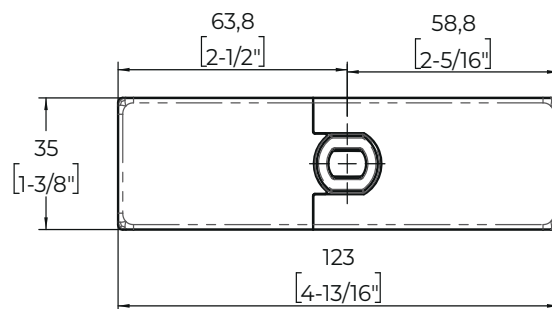
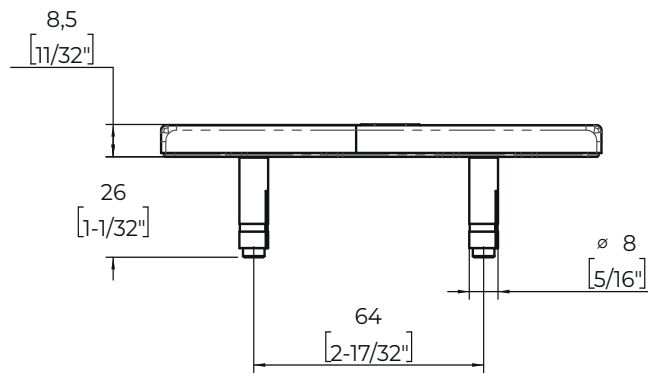
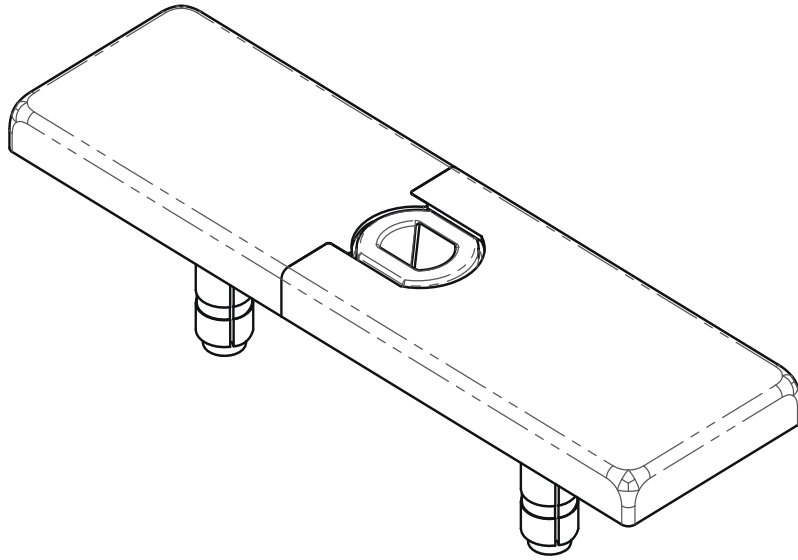

Finiture
Finishing
Acabados



! Inclusa nel kit 4FRXK, non inclusa in 42800
Included with the KIT 4FRXK, not included in 42800
Incluido con el KIT 4FRXK, no incluido en 42800

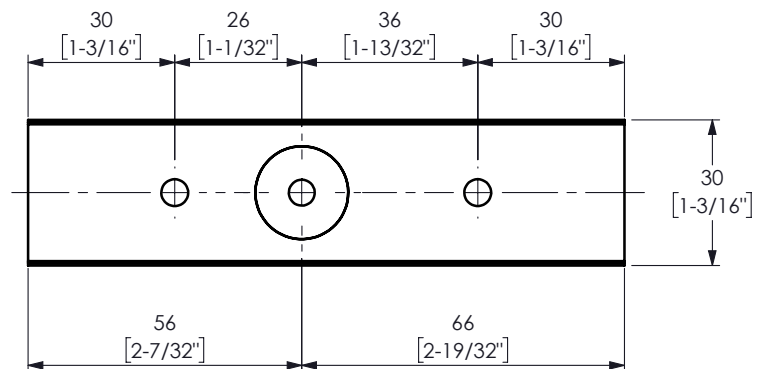
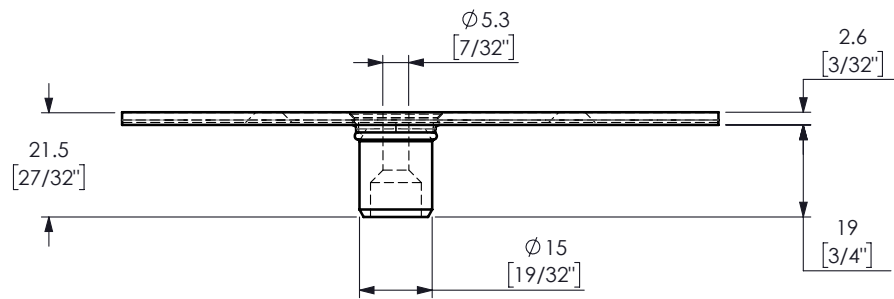
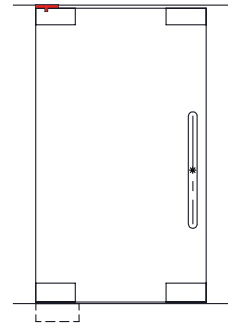
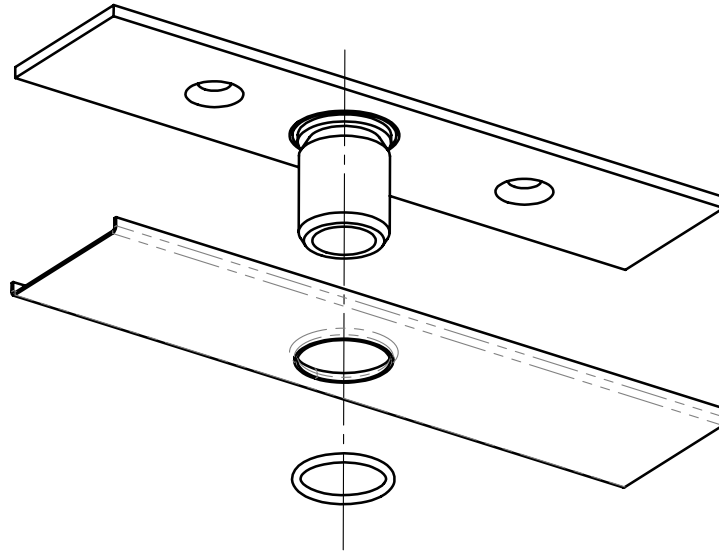

Finiture Finishing Acabados	
610	710
611	712
613	810
614	812
620	

Cod. 4FWXN

Applicazione per vetro a bilico
Displaced glass application
Aplicación desplazada por vidrio



Larghezza max dell'anta
Max door width
Ancho de la puerta
1000 mm
39-3/8"



Spessore vetro
Glass thickness
Espesor del vidrio
8 ÷ 14 mm
5/16 ÷ 9/16"



Peso max
Door weight
Peso máximo
100 kg
220 Lbs



Testata
Tested
Testado
500.000 cicli
cycle - ciclos

KIT

4FWXK

KIT Cerniera idraulica
KIT Hydraulic hinge
KIT Bisagra hidráulica

4FWXN

Cerniera idraulica
Hydraulic hinge
Bisagra hidráulica

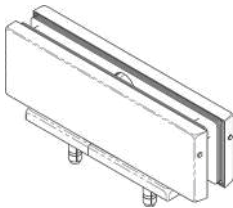

42900

Cerniera libera
Dummy hinge
Bisagra libre



4FR9N

Piastrina a pavimento
Plate
Plaqueta

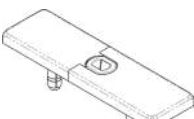

10190

Perno di rotazione
Pivot
Rotación

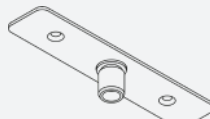

Inclusa con 4FRXN e 4FWXN
Included with 4FRXN and 4FWXN
Incluido con 4FRXN y 4FWXN

*Disponibile in finitura 810. Per altre finiture utilizzare art.10180.
Available in 810 finish. For different finishes use art.10180.
Disponibile en acabado 810. Para diferentes acabados utilizar art.10180.

KIT

10190

Perno di rotazione
Pivot
Rotación

42900

Cerniera libera
Dummy hinge
Bisagra libre

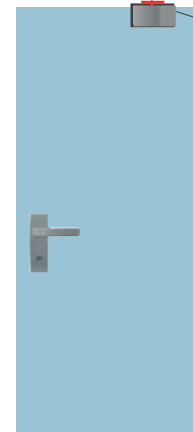

4FWXN

Cerniera idraulica
chiudiporta
Hydraulic hinge
Bisagra hidráulica

4FR9N

Piastrina a pavimento
Plate
Plaqueta

Finiture
Finishing
Acabados



■ Possibile posizione della porta
Possible door position
Posible posición de la puerta

■ Chiusura controllata
Self-closing
Cierre controlado

■ Posizione libera
Free standing
Posición libre

● Stop

Range di regolazione della posizione
Position adjustment range
Rango de regulación de la posición

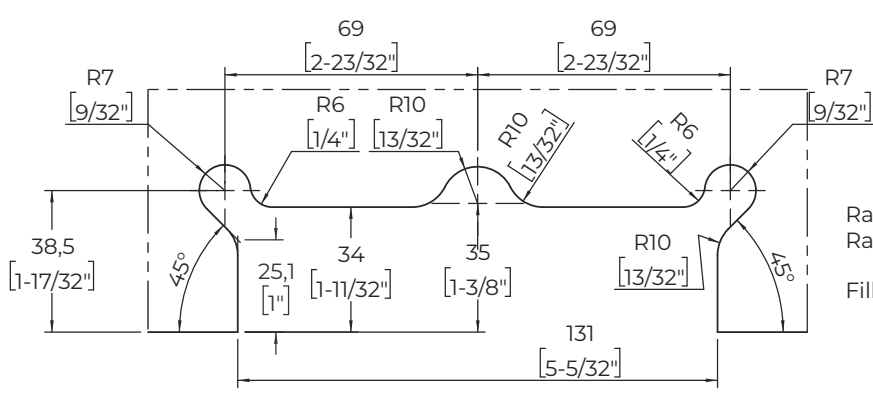
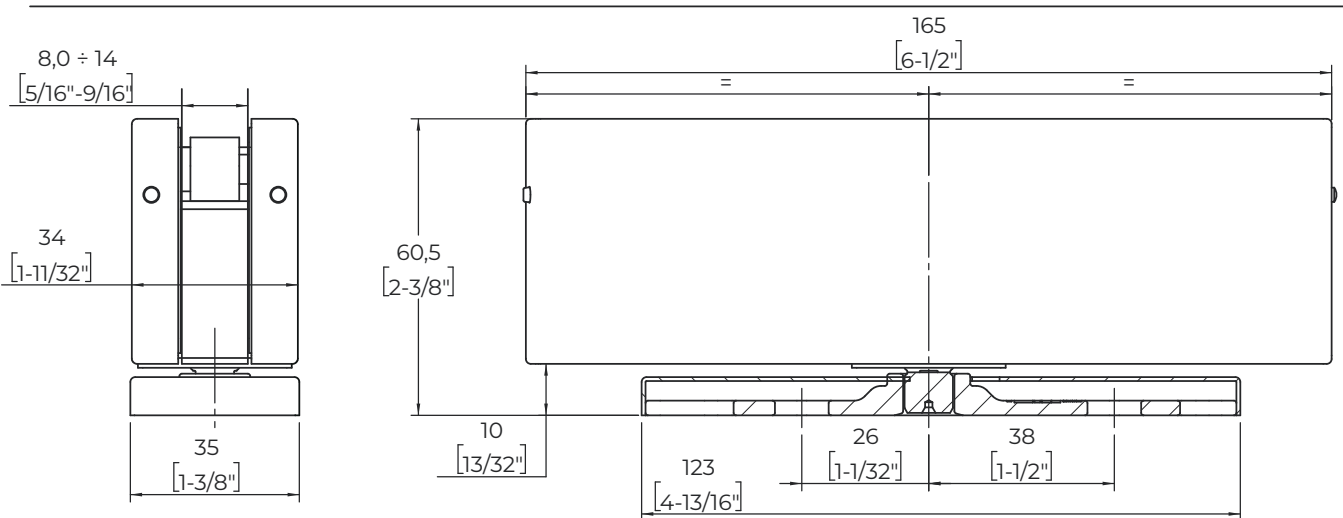
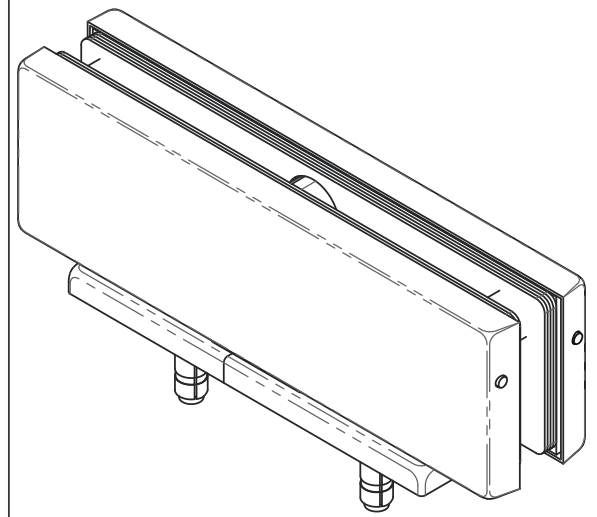
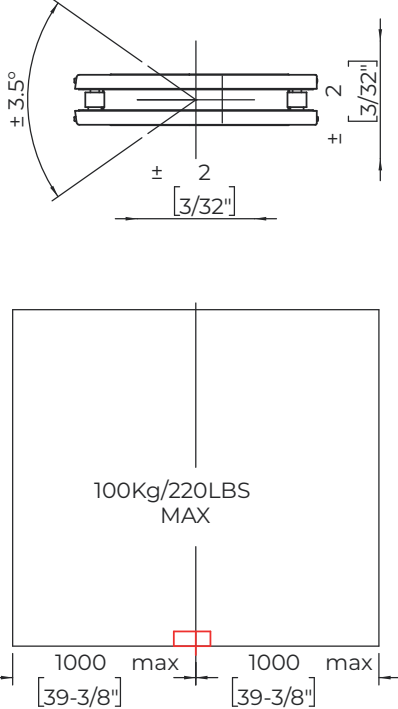
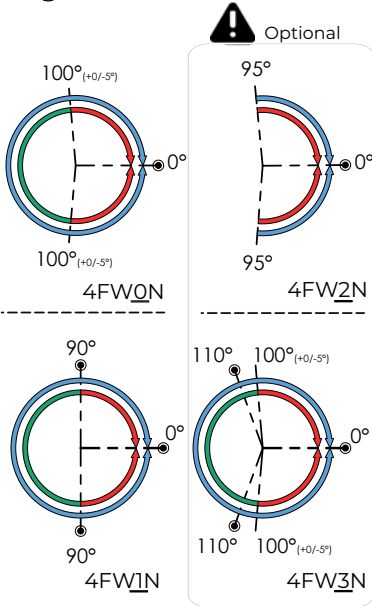
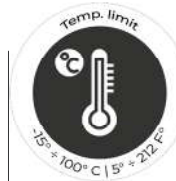

Raggi non quotati
 Radios non dimensionados
 R10
 Fillets unquoted
 R [3/8"]

Applicazione per vetro a bilico
Displaced glass application
Aplicación desplazada por vidrio

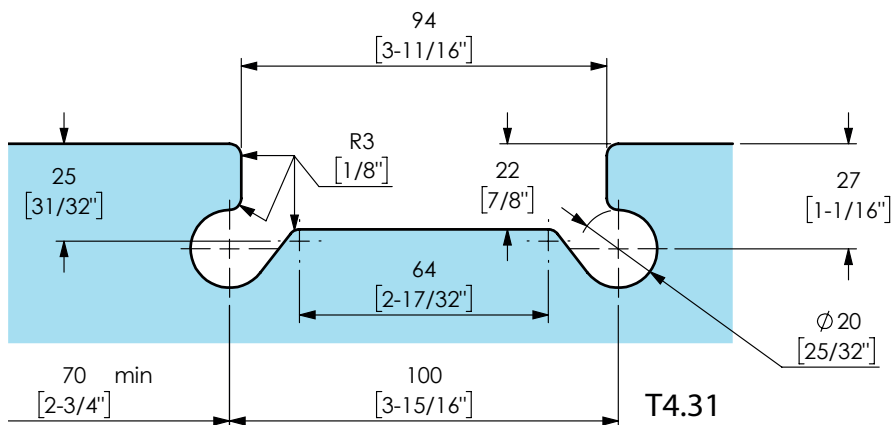
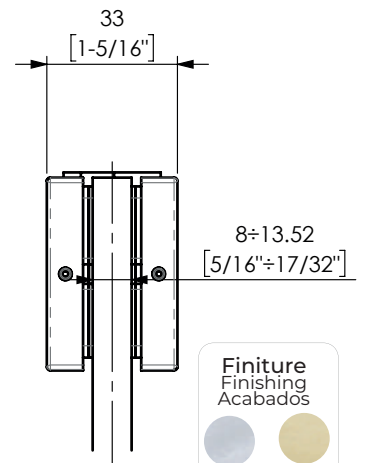
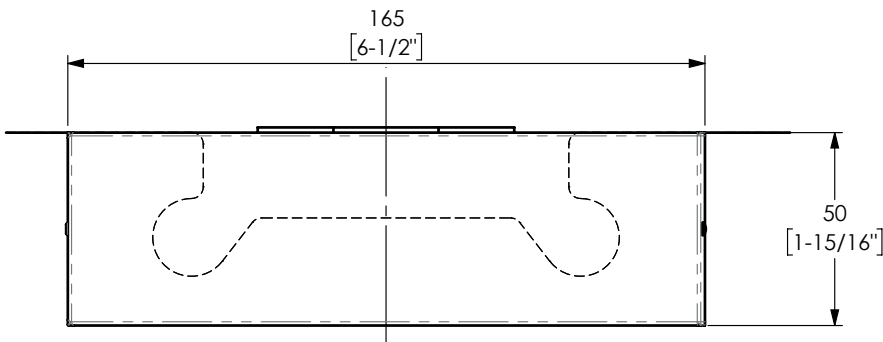
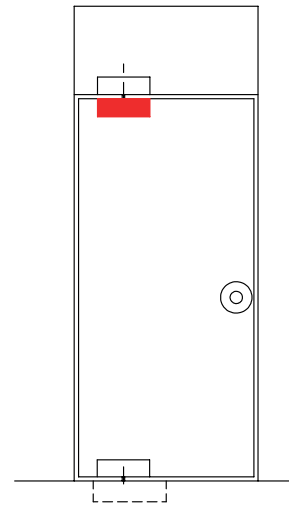
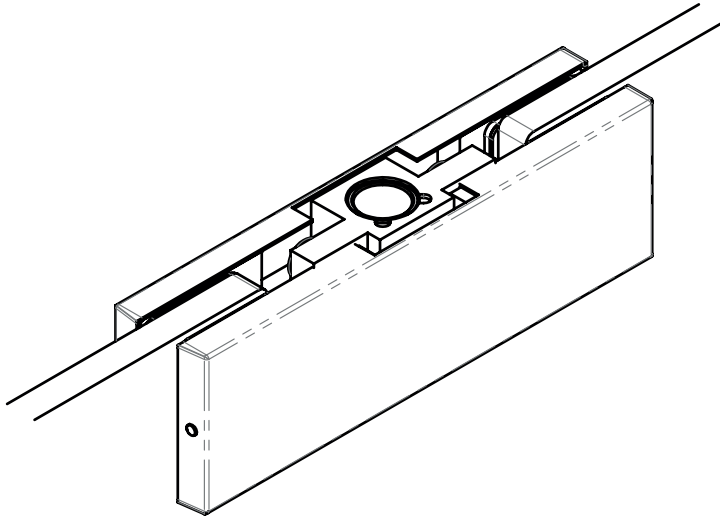

Finiture
Finishing
Acabados

610	710
611	712
613	810
614	812
620	

! Inclusa con 4FRXN e 4FWXN
Included with 4FRXN and 4FWXN
Incluido con 4FRXN y 4FWXN

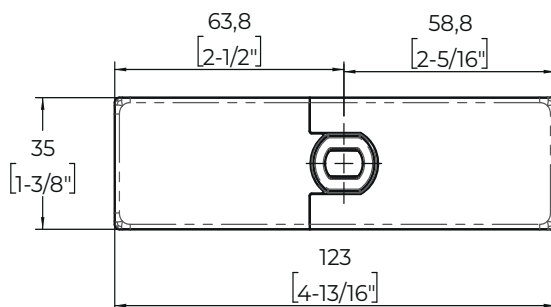
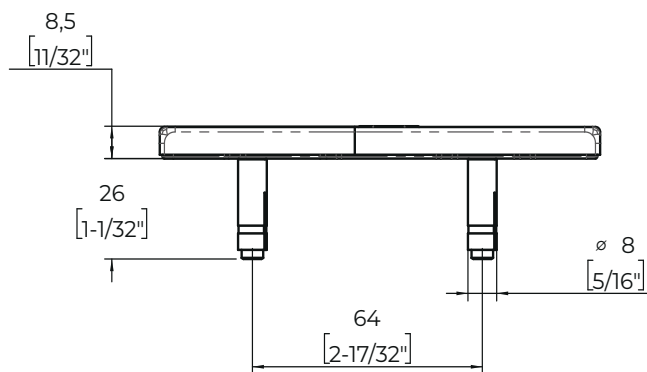
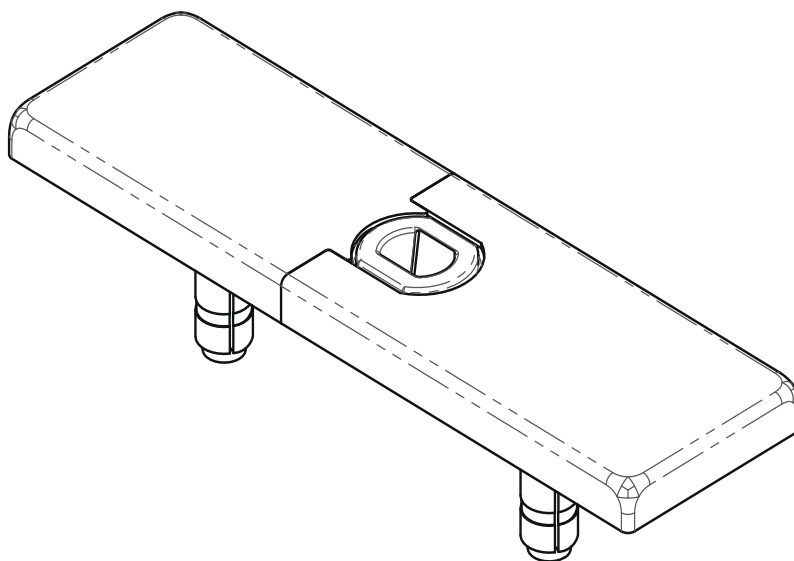

Finiture
Finishing
Acabados

- | | |
|-----|-----|
| | |
| 610 | 710 |
| | |
| 611 | 712 |
| | |
| 613 | 810 |
| | |
| 614 | 812 |
| | |
| 620 | |

! Inclusa nel kit 4FWXK, non inclusa in 42900
Included with the KIT 4FWXK, not included in 42900
Incluido con el KIT 4FWXK, no incluido en 42900

*Disponibile in finitura 810. Per altre finiture utilizzare art.10180.
Available in 810 finish. For different finishes use art.10180.
Disponibile en acabado 810. Para diferentes acabados utilizar art. 10180.

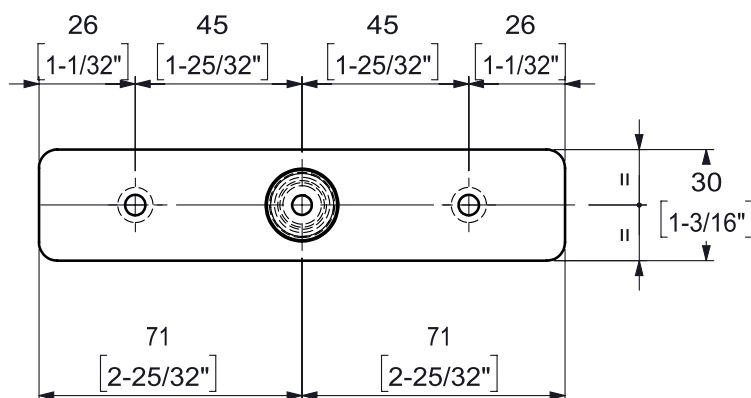
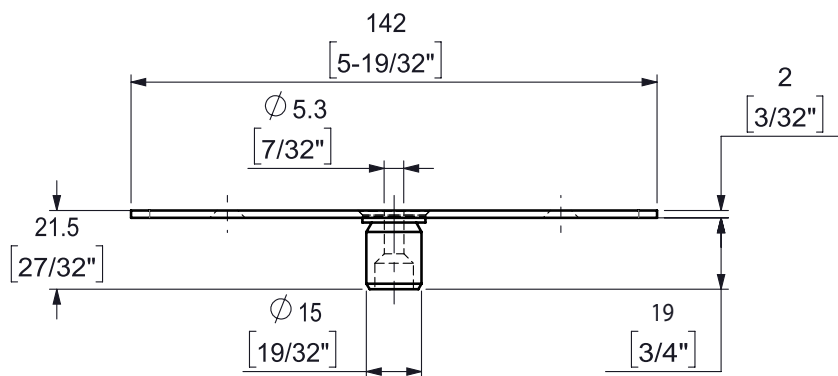
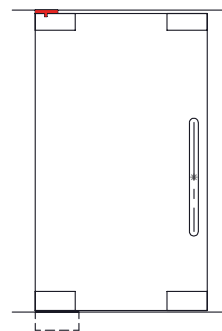
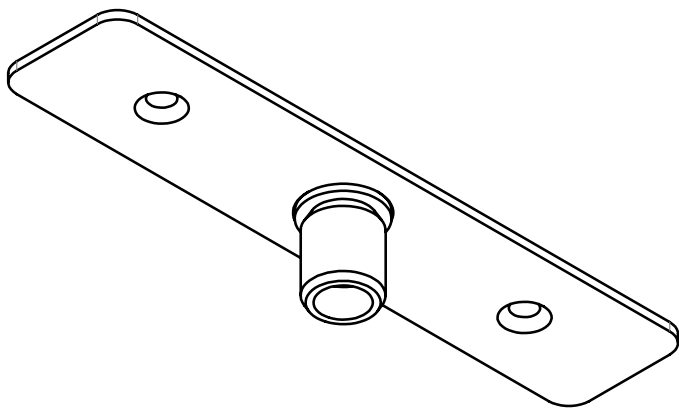

Applicazione per porte con profilo o per porte in legno
In profile or wooden door application
Aplicación en puerta con perfiles y en puertas de madera

4FXXN

Porte con profilo | Framed doors | Puertas con perfil

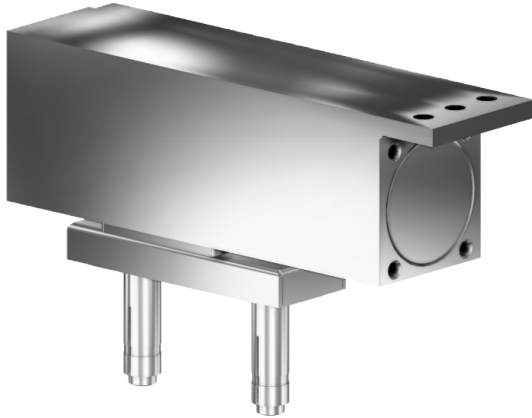

Larghezza max dell'anta
Max door width
Ancho de la puerta
1000 mm
39-3/8"

Peso max
Door weight
Peso máximo
100 kg
220 Lbs

Testata
Tested
Testado
500.000 cicli -
cycle - ciclos

4FTXN

Porte in legno | Wooden doors | Puertas de madera



KIT

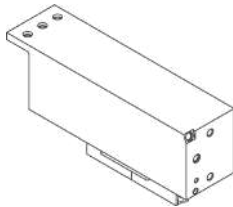

4FXXN
Cerniera idraulica per porte con
profili
Hydraulic hinge for framed doors
Bisagra hidráulica para puertas
con perfiles

Opzionale | Optional | Opcional

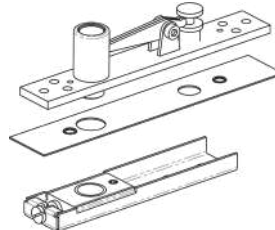

32400
Perno di rotazione
Pivot
Rotación

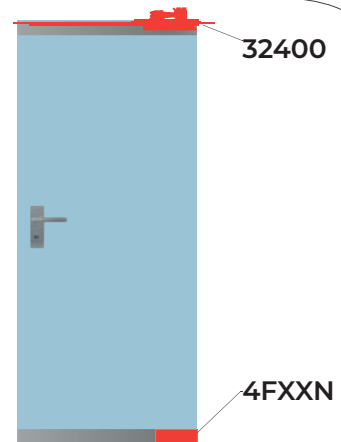

Finiture Finishing Acabados

- 610
- 710
- 611
- 712
- 613
- 810
- 614
- 812
- 620

KIT

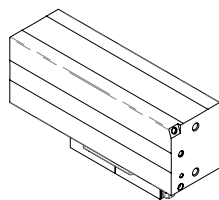

4FTXN
Cerniera idraulica per porte in
legno
Hydraulic hinge for wooden doors
Bisagra hidráulica para puertas
de madera

Opzionale | Optional | Opcional

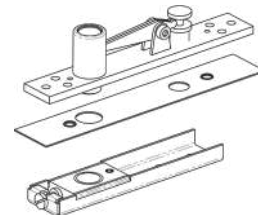

32400
Perno di rotazione
Pivot
Rotación



Cod. 4FXXN

Applicazione per porte con profili
In frame door application
Aplicación en puertas con perfiles

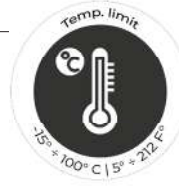

- Possibile posizione della porta
Possible door position
Posible posición de la puerta
- Chiusura controllata
Self-closing
Cierre controlado
- Posizione libera
Free standing
Posición libre
- Stop

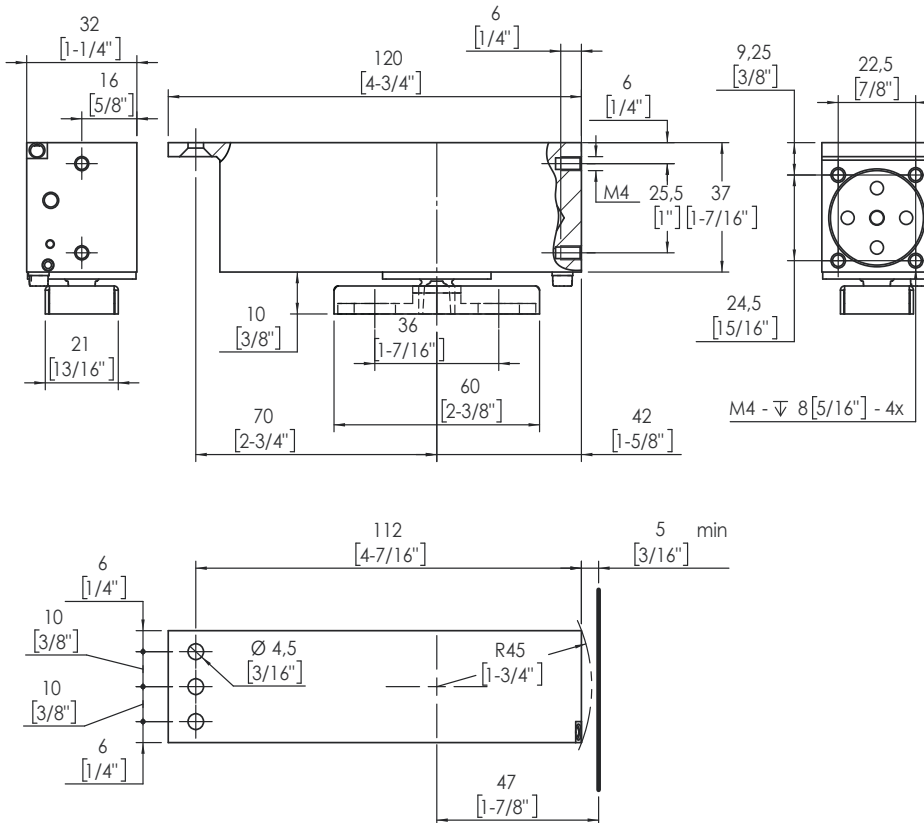
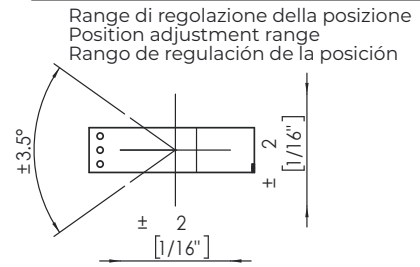
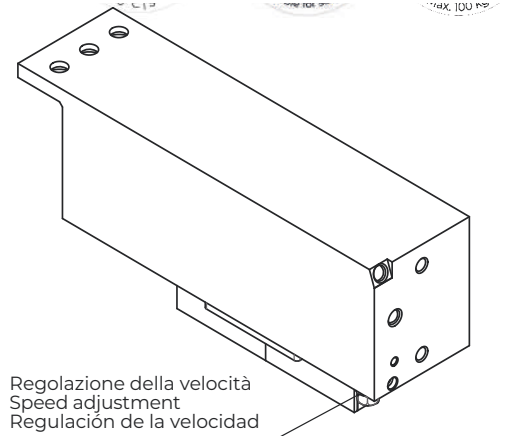
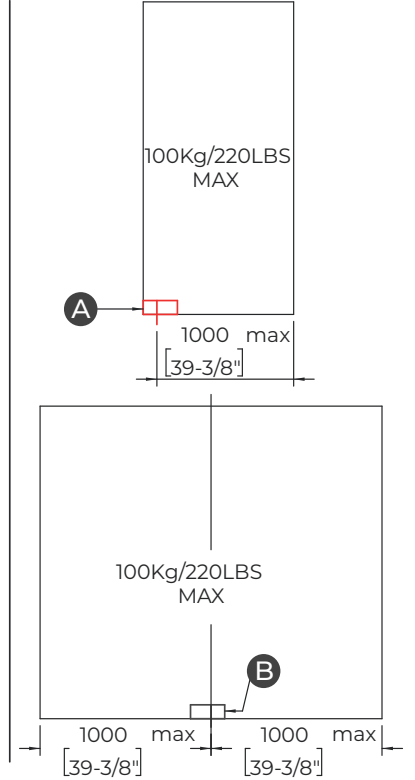
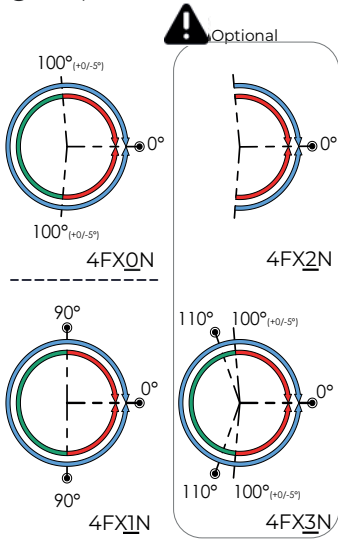

Staffa di fissaggio
Brackets type
Angulo de ensamblaje

ANGULAR

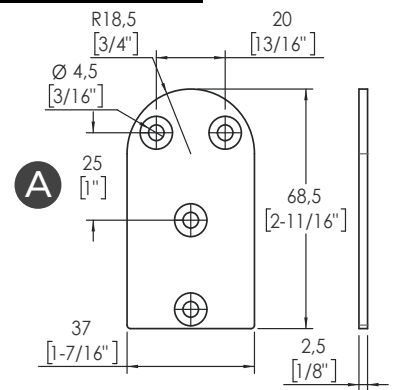

PIVOT OFF-SET

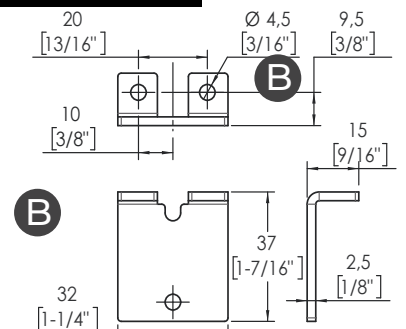

C Personalizzabile a richiesta
Custom on demand
Personalizado bajo pedido

! Specificare in fase d'ordine
Specify at order
Especificar en el order

Applicazione per porte in legno
In wooden door application
Aplicación en loa puertas de madera

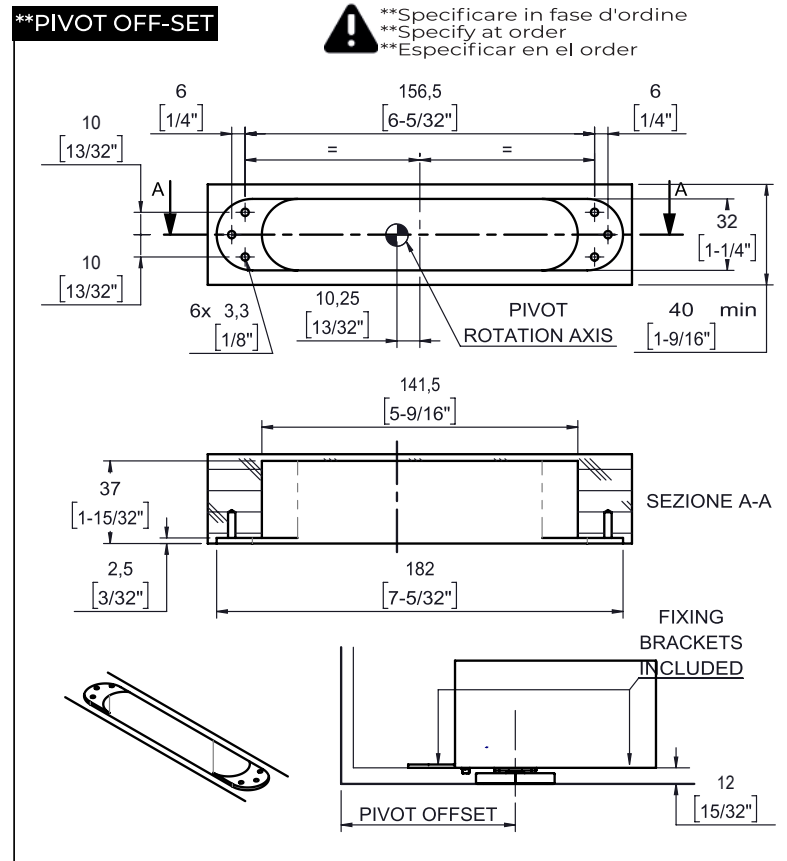
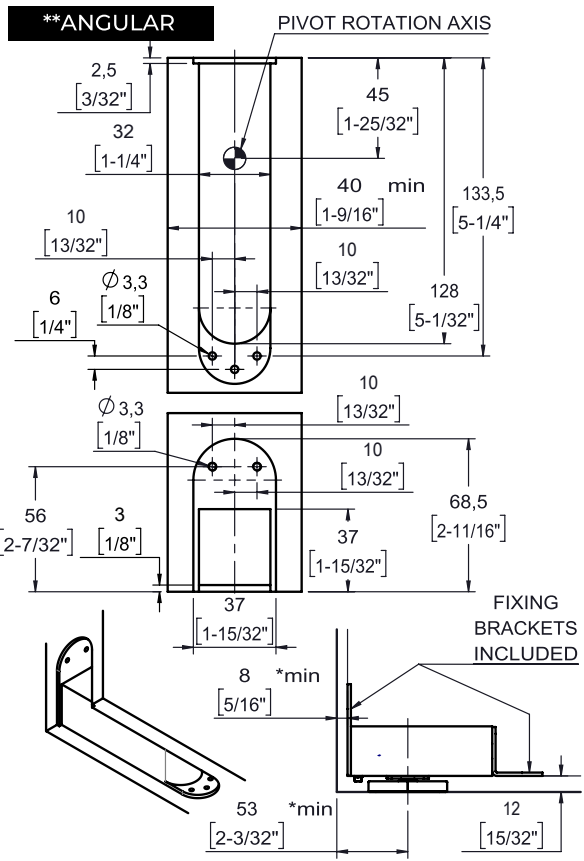
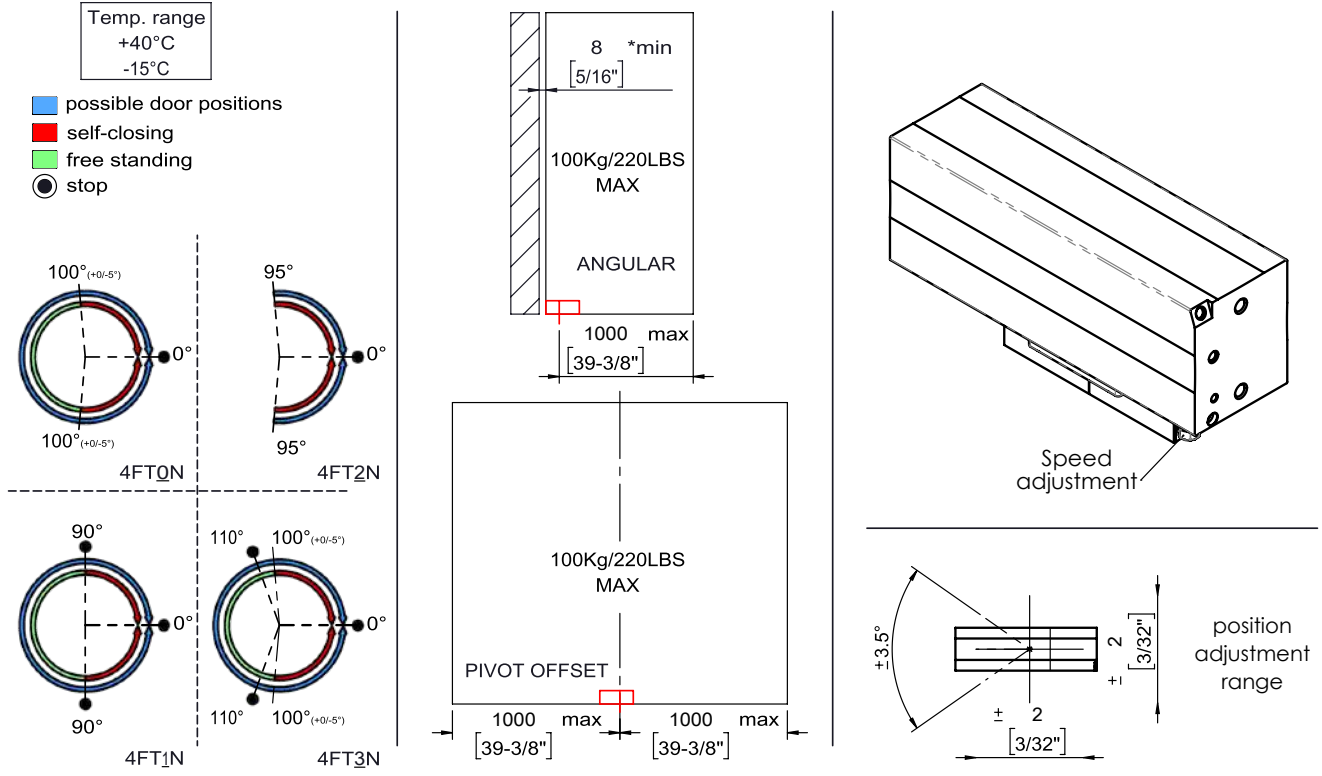

*For doors up to 50 mm [1" 31/32] wide.

Applicazione in porte con profilo o per porte in legno
In profile or wooden door application
Aplicación en puertas con perfiles y para puertas de madera

! Opzionale | Optional | Opcional
Non incluso in 4FXXN e 4FTXN
Not included in 4FXXN and 4FTXN
No incluido en 4FXXN y 4FTXN

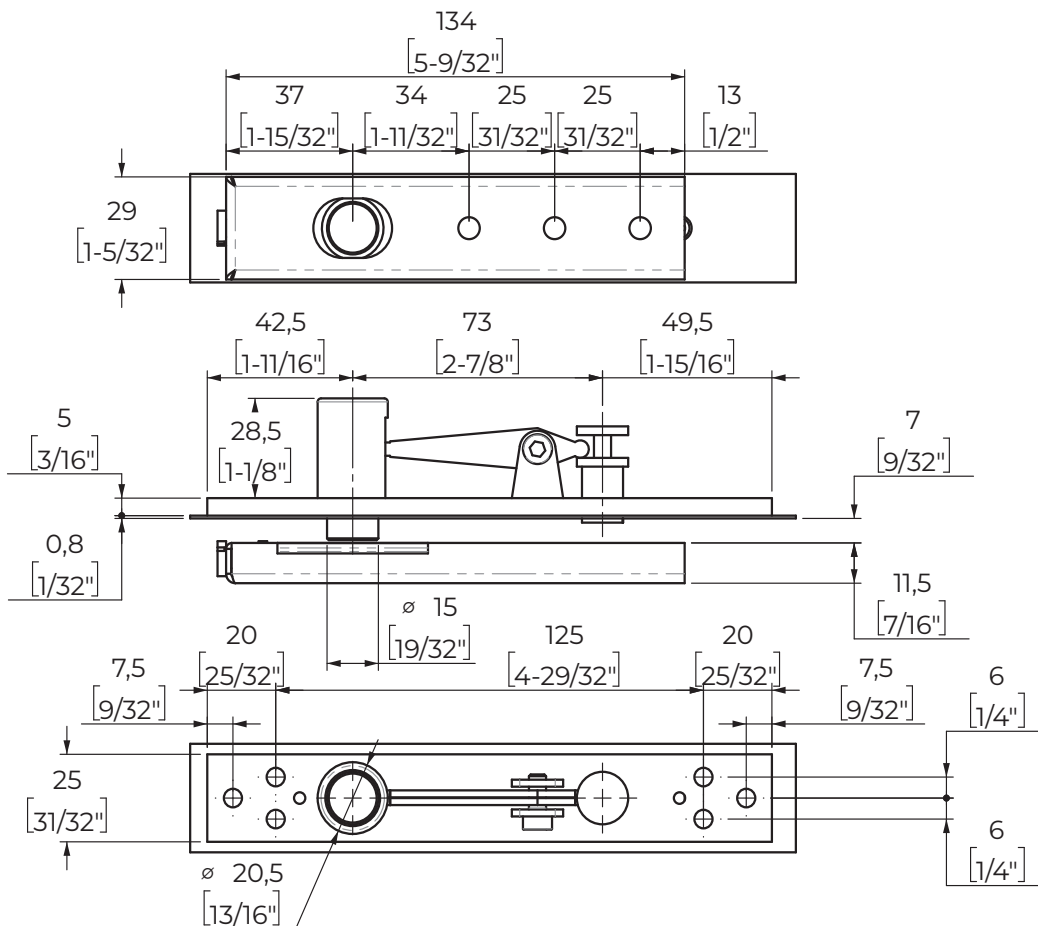
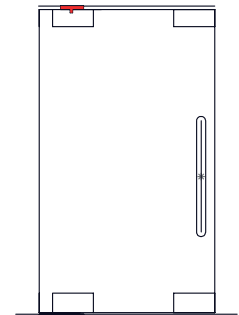
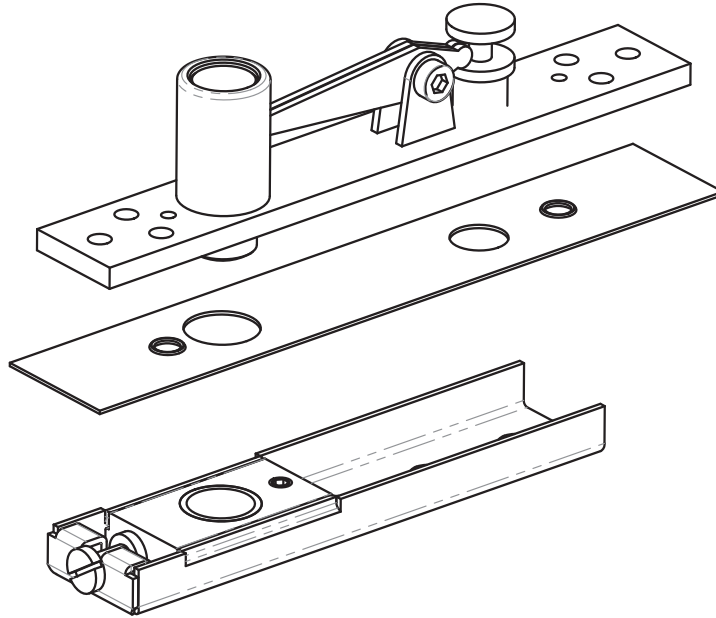



Cod. 4LCXS

Applicazione vetro-muro con aletta centrale
Glass to wall application with central wing
Aplicación vidrio-pared con aleta central



Larghezza max dell'anta
Max door width
Ancho de la puerta
1000 mm
39-3/8"

Spessore vetro
Glass thickness
Espesor del vidrio
8 ÷ 14 mm
5/16 ÷ 9/16"

Peso max
Door weight
Peso máximo
100 kg
220Lbs

Testata
Tested
Testado
500.000 cicli
cycle - ciclos

4LC1S
Cerniera idraulica
Hydraulic hinge
Bisagra hidráulica



4LCDS
Cerniera libera
Dummy hinge
Bisagra libre



Finiture Finishing Acabados	
610	611
613	710
614	712
615	810
620	812

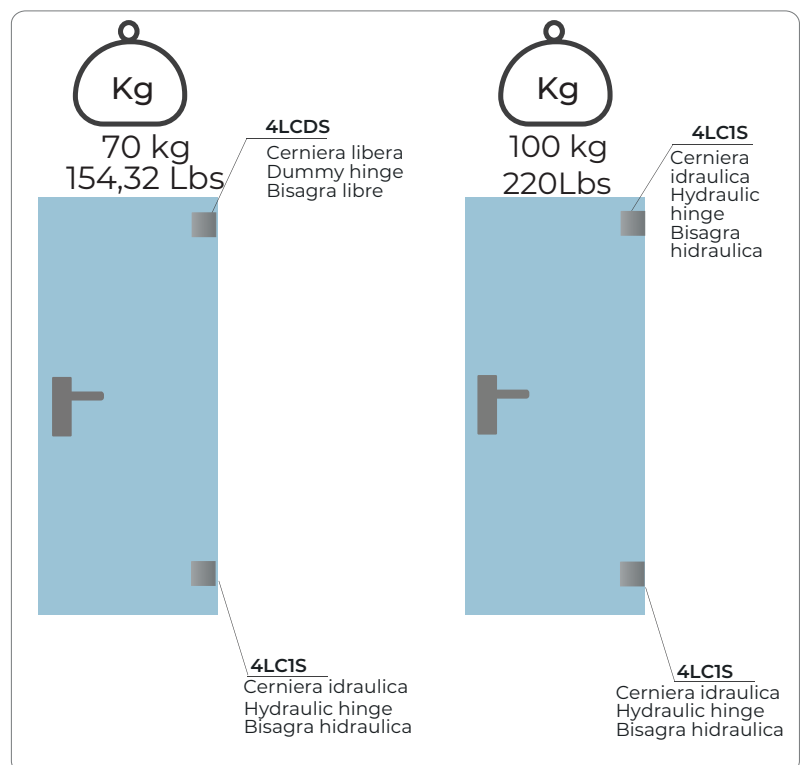

Applicazione vetro-muro con aletta centrale
Glass to wall application with central wing
Aplicación vidrio-pared con aleta central

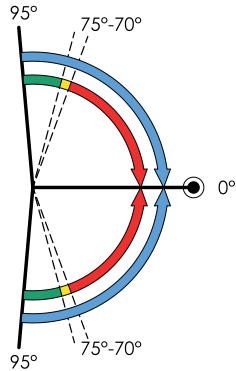

- Possibile posizione della porta
Possible door position
Posible posición de la puerta
- Chiusura controllata
Self-closing
Cierre controlado
- Avvio chiusura controllata
Start closing
Inicio cierre controlado
- Posizione libera
Free standing
Posición libre
- Stop

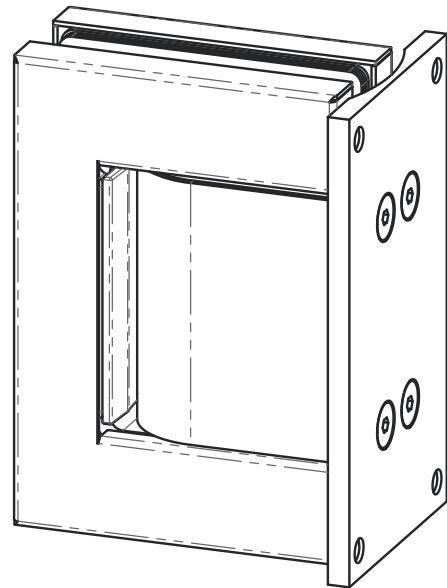

<p>* 4LCDS Cerniera libera Dummy hinge Bisagra libre</p> <p>MAX 70Kg 154lbs</p> <p>max. 900mm [35-7/16"]</p>	<p>** 4LC1S Cerniera idraulica Hydraulic hinge Bisagra hidráulica</p> <p>MAX 100Kg 220lbs</p> <p>max. 1000mm [39-3/8"]</p>
---	---

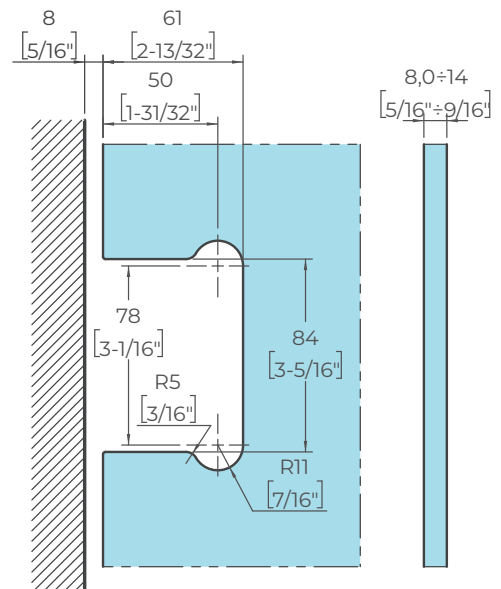
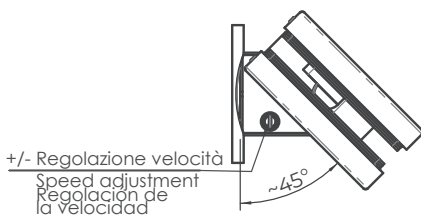
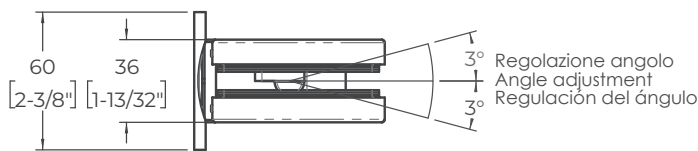
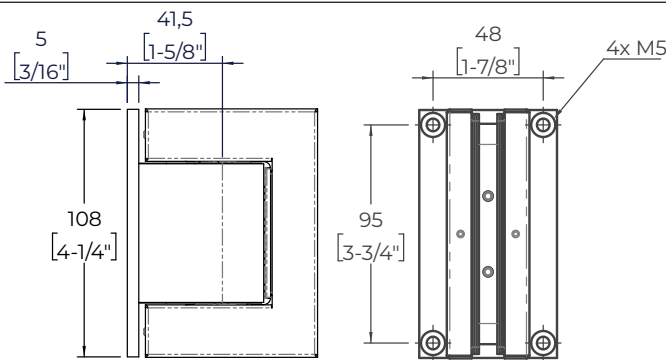

Cod. 4LLXS

Applicazione vetro-muro con aletta decentrata
Glass to wall application with off-set wing
Aplicación vidrio-pared con aleta desplazada



Larghezza max dell'anta
Max door width
Ancho de la puerta

1000 mm
39-3/8"



Spessore vetro
Glass thickness
Espesor del vidrio

8 ÷ 14 mm
5/16 ÷ 9/16"



Peso max
Door weight
Peso máximo

100 kg
220Lbs



Testata
Tested
Testado

500.000 cicli
cycle - ciclos

4LLIS
Cerniera idraulica
Hydraulic hinge
Bisagra hidráulica

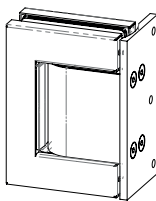

4LLDS
Cerniera libera
Dummy hinge
Bisagra libre

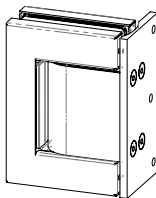

Finiture
Finishing
Acabados

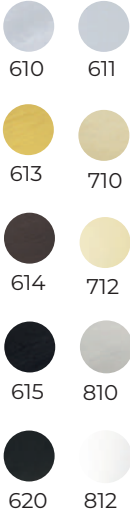

70 kg
154,32 Lbs

4LLDS
Cerniera libera
Dummy hinge
Bisagra libre



100 kg
220Lbs

4LLIS
Cerniera idraulica
Hydraulic hinge
Bisagra hidráulica

4LLIS
Cerniera idraulica
Hydraulic hinge
Bisagra hidráulica

4LLIS
Cerniera idraulica
Hydraulic hinge
Bisagra hidráulica

Applicazione vetro-muro con aletta decentrata
Glass to wall application with off-set wing
Aplicación vidrio-pared con aleta desplazada

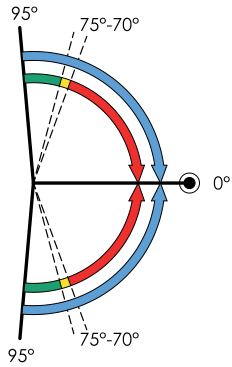

- Possibile posizione della porta
Possible door position
Posible posición de la puerta
- Chiusura controllata
Self-closing
Cierre controlado
- Avvio chiusura controllata
Start closing
Inicio cierre controlado
- Posizione libera
Free standing
Posición libre
- Stop

*	**
MAX 70Kg 154lbs	MAX 100Kg 220lbs
**	**
max 900mm [35-7/16"]	max 1000mm [39-3/8"]

- * 4LLDS
Cerniera libera
Dummy hinge
Bisagra libre
- ** 4LLIS
Cerniera idraulica
Hydraulic hinge
Bisagra hidráulica

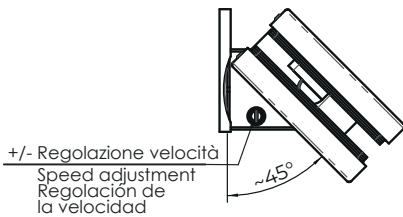
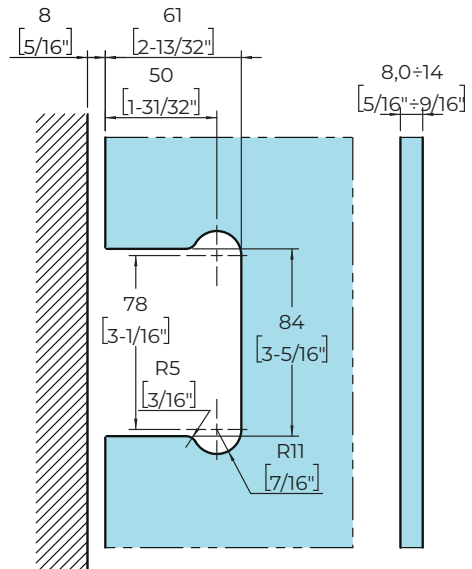
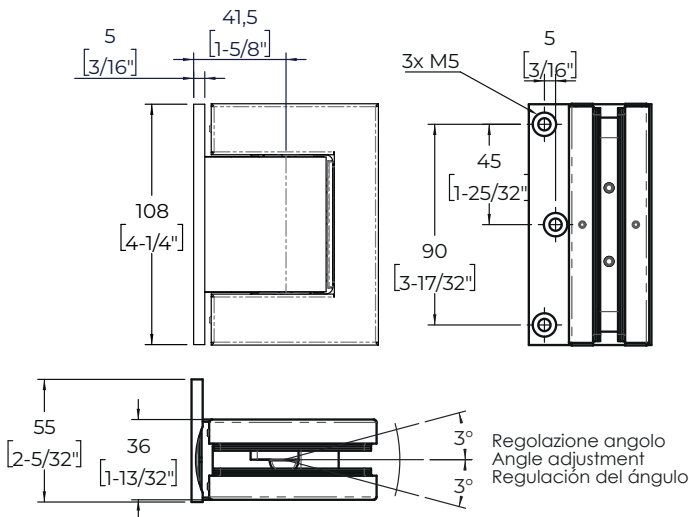
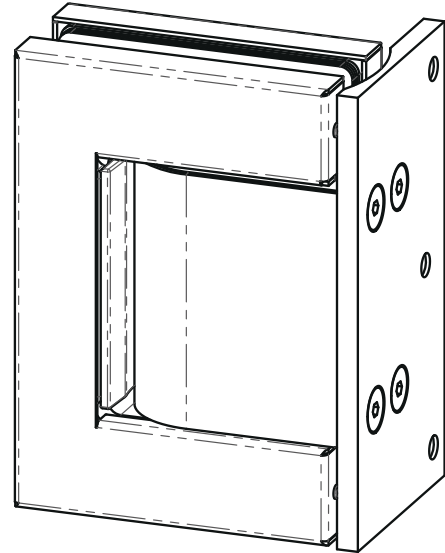

Cod. 4LVXS

Applicazione vetro-vetro
Glass to glass application
Aplicación vidrio-vidrio



Larghezza max dell'anta
Max door width
Ancho de la puerta
1000 mm
39-3/8"



Spessore vetro
Glass thickness
Espesor del vidrio
8 ÷ 14 mm
5/16 ÷ 9/16"



Peso max
Door weight
Peso máximo
100 kg
220Lbs



Testata
Tested
Testado
500,000 cicli
cycle - ciclos

- Finiture**
Finishing
Acabados
- 610 611
 - 613 710
 - 614 712
 - 615 810
 - 620 812

4LVIS
Cerniera idraulica
Hydraulic hinge
Bisagra hidráulica

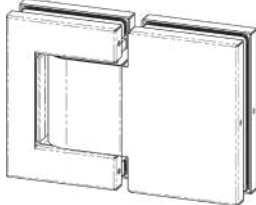

4LVDS
Cerniera libera
Dummy hinge
Bisagra libre

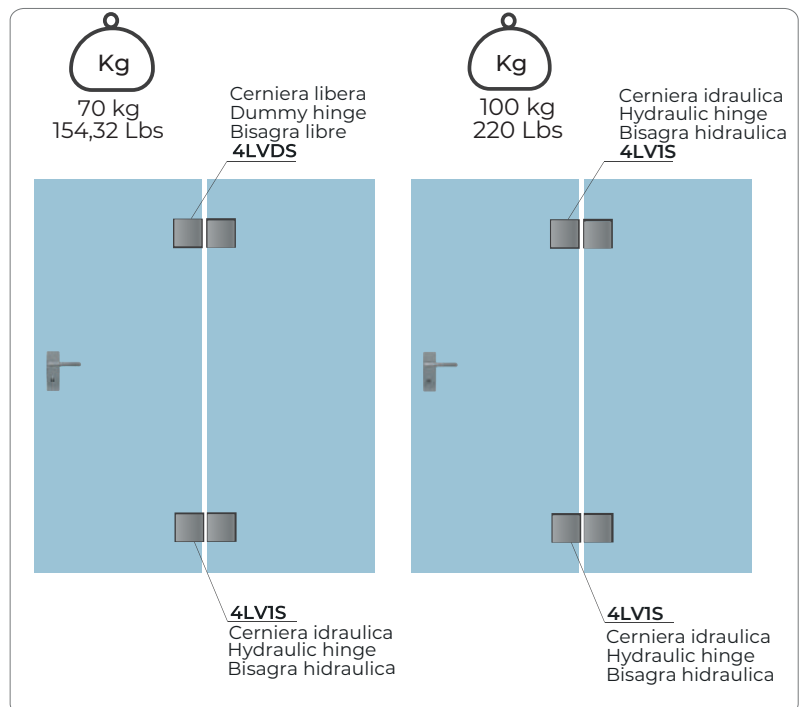
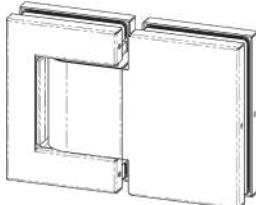

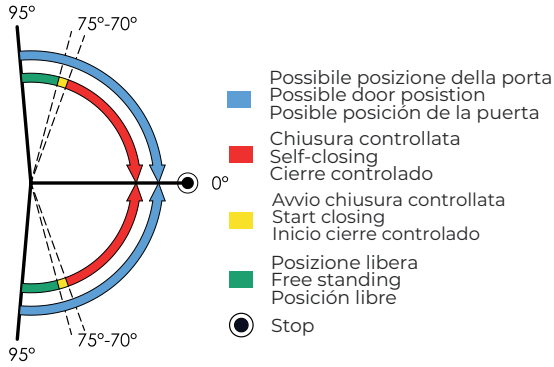

*	**	* 4LVDS Cerniera libera Dummy hinge Bisagra libre
**	**	
MAX 70Kg 154lbs	MAX 100Kg 220lbs	** 4LVIS Cerniera idraulica Hydraulic hinge Bisagra hidráulica
max 900mm [35-7/16"]	max 1000mm [39-3/8"]	

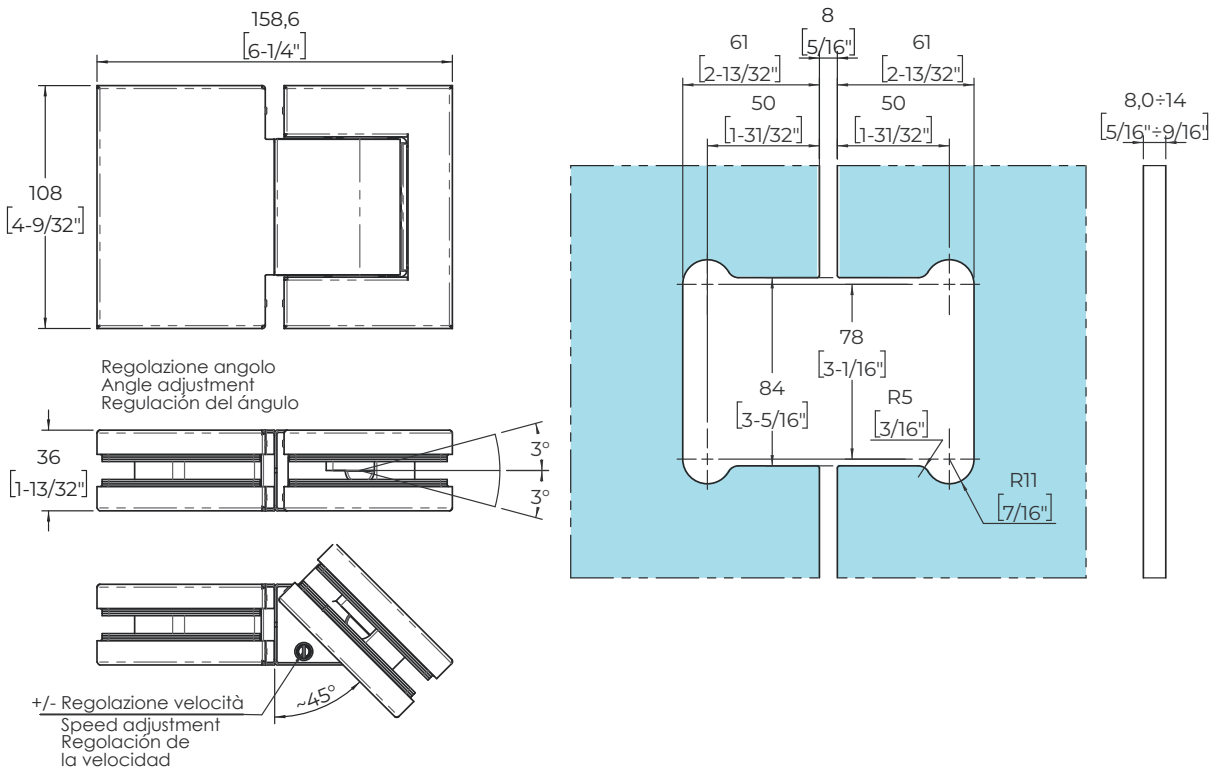
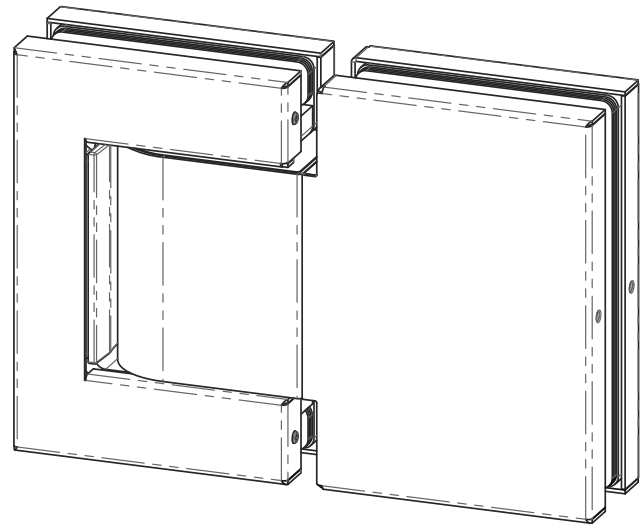

Cod. 4LVXS

Applicazione vetro-vetro
Glass to glass application
Aplicación vidrio-vidrio



Larghezza max dell'anta
Max door width
Ancho de la puerta

1000 mm
39-3/8"



Spessore vetro
Glass thickness
Espesor del vidrio

8 ÷ 14 mm
5/16 ÷ 9/16"



Peso max
Door weight
Peso máximo

100 kg
220Lbs



Testata
Tested
Testado

500.000 cicli
cycle - ciclos

Finiture
Finishing
Acabados

- 610
- 611
- 613
- 680
- 614
- 615
- 620

4LADS

Cerniera idraulica
Hydraulic hinge
Bisagra hidráulica

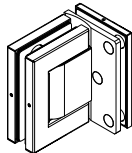

4LAIS

Cerniera libera
Dummy hinge
Bisagra libre

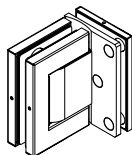

70 kg
154,32 Lbs

Cerniera libera
Dummy hinge
Bisagra libre

4LADS

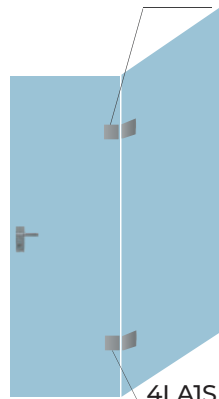

4LAIS

Cerniera idraulica
Hydraulic hinge
Bisagra hidráulica

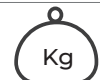

100 kg
220 Lbs

Cerniera idraulica
Hydraulic hinge
Bisagra hidráulica

4LAIS

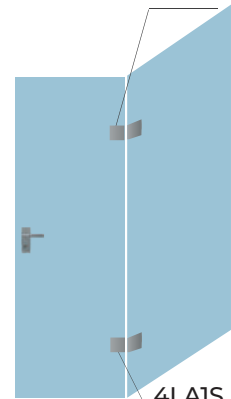

4LAIS

Cerniera idraulica
Hydraulic hinge
Bisagra hidráulica

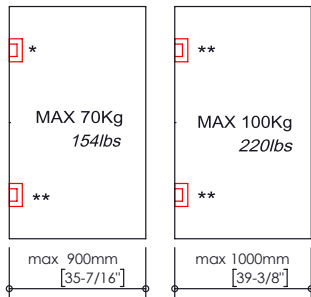
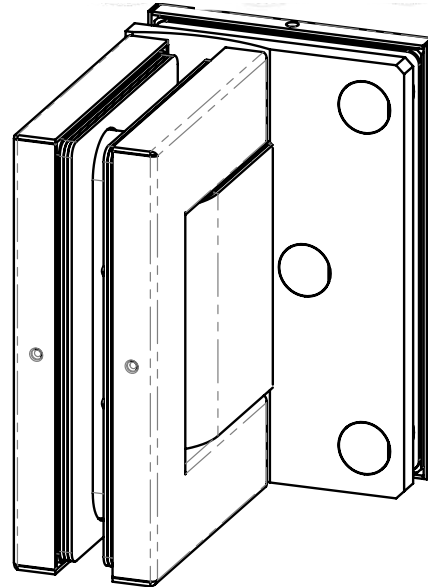
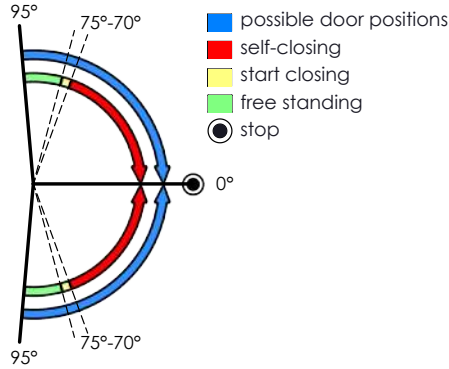

* **4LADS**

Dummy

** **4LA1S**

Hydraulic

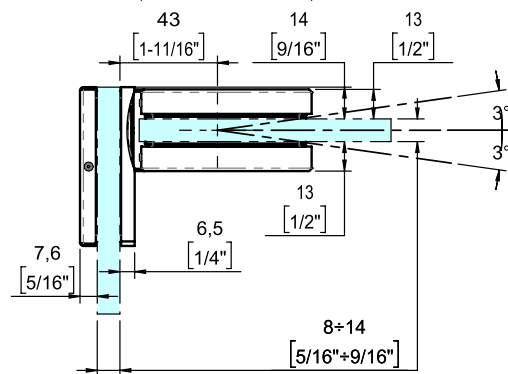
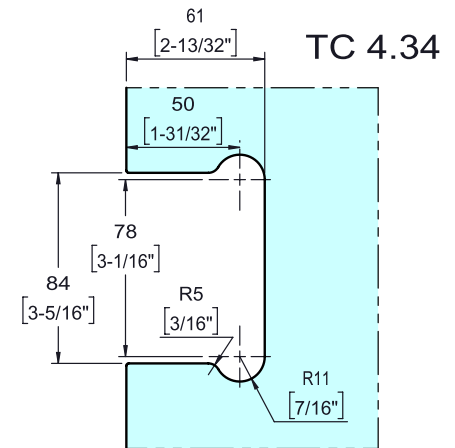
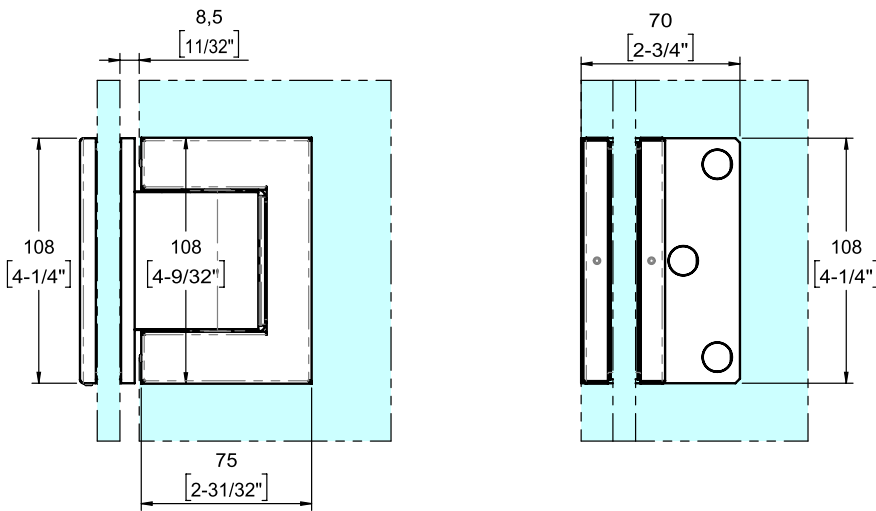

Angle adjustment

+/- speed adjustment

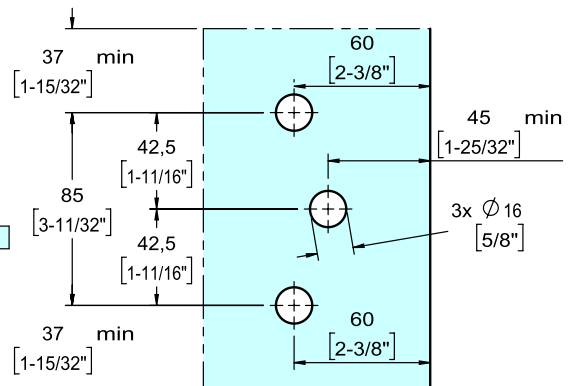
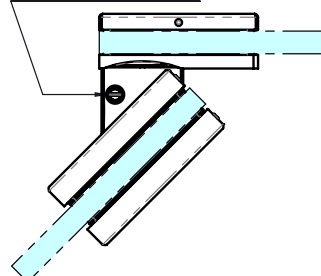

TC 4.37

Cod. 4L8XS

Applicazione vetro-muro o su profilo (41AL)
Glass to wall or profile (41AL) application
Aplicación vidrio-pared o con perfil (41AL)



Larghezza max dell'anta
Max door width
Ancho de la puerta

1000 mm
39-3/8"



Spessore vetro
Glass thickness
Espesor del vidrio

8 ÷ 14 mm
5/16 ÷ 9/16"



Peso max
Door weight
Peso máximo

100 kg
220Lbs



Testata
Tested
Testado

500,000 cicli
cycle - ciclos

Finiture
Finishing
Acabados



610 611



613 680



614 615



615 620

4L81S

Cerniera idraulica chiudiporta
Hydraulic hinge
Bisagra hidráulica



4L8DS

Cerniera libera
Dummy hinge
Bisagra libre

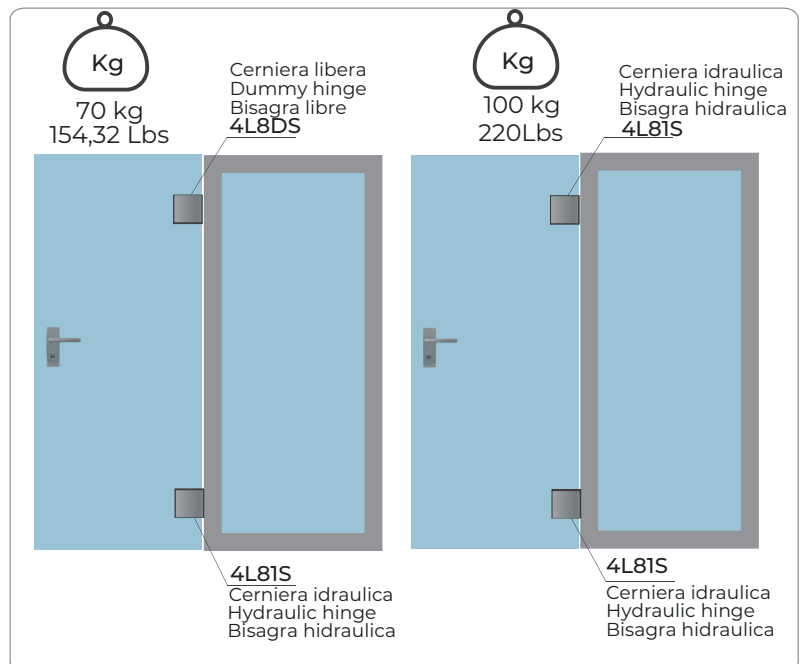
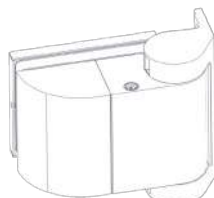

Applicazione vetro-muro o su profilo (41AL)
Glass to wall or profile (41AL) application
Aplicación vidrio-pared o con perfil (41AL)

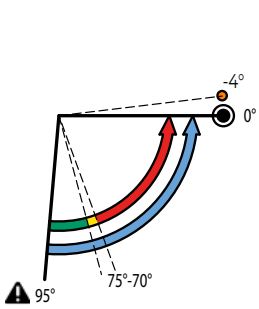

- Possibile posizione della porta
Possible door position
Posible posición de la puerta
- Chiusura controllata
Self-closing
Cierre controlado
- Avvio chiusura controllata
Start closing
Inicio cierre controlado
- Posizione libera
Free standing
Posición libre
- Stop
- Precarica
Preload
Precarga
- ⚠ Aperture violente oltre i 95° potrebbero provocare lo scardinamento.
Violent opening further than 95° could unhinge the door.
Apertura violenta además de 95°, podría causar daño.

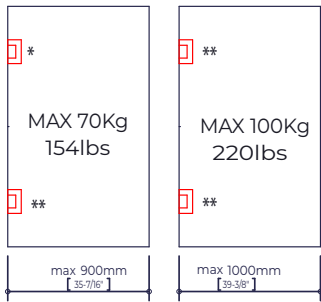
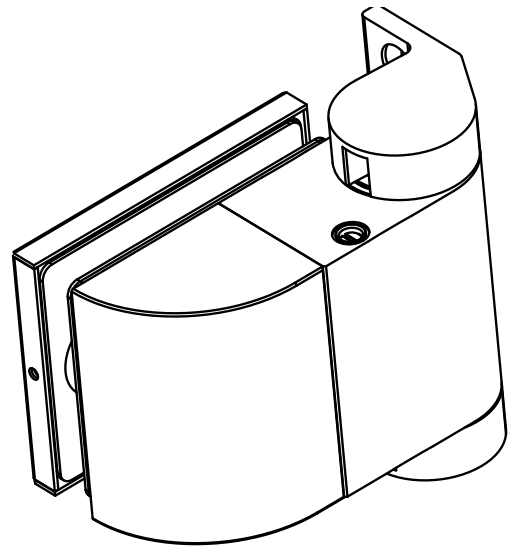

* 4L8DS

Cerniera libera
Dummy hinge
Bisagra libre

** 4L8IS

Cerniera idraulica
Hydraulic hinge
Bisagra hidráulica

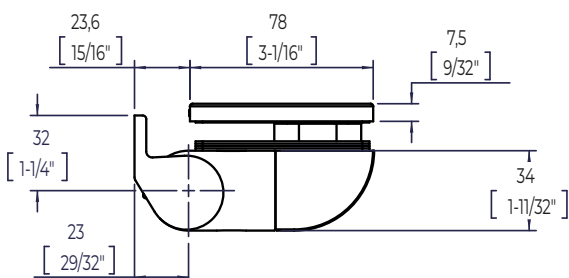
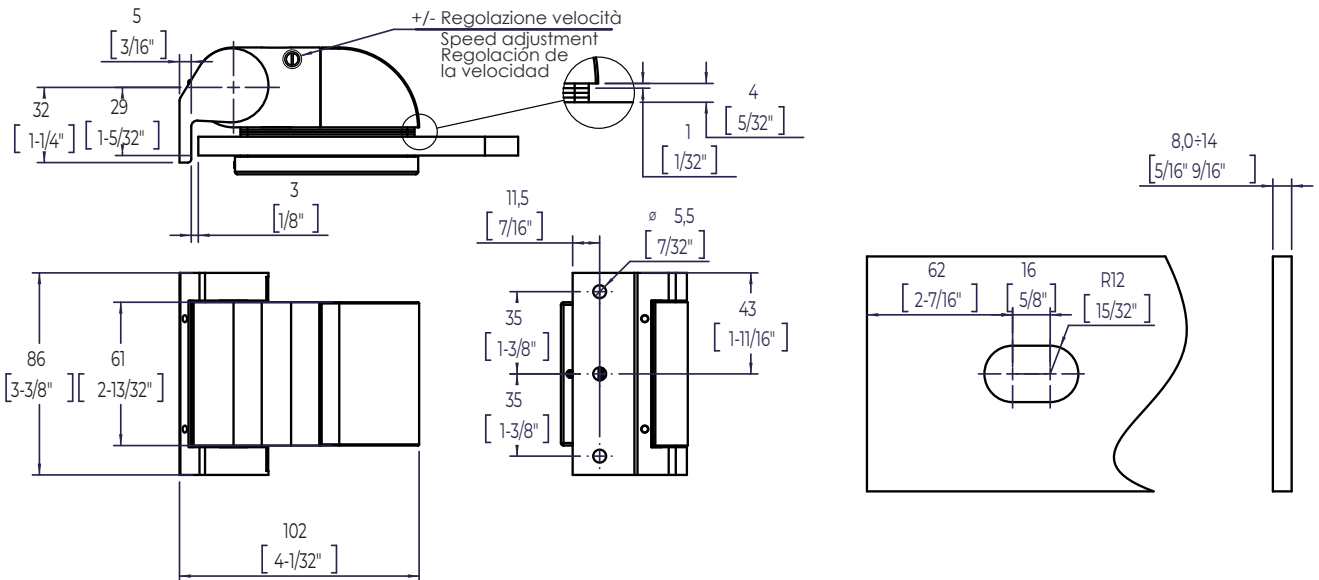

ESEMPIO SU PARTIZIONE
Example on glass wall partition
Ejemplo sobre particióne

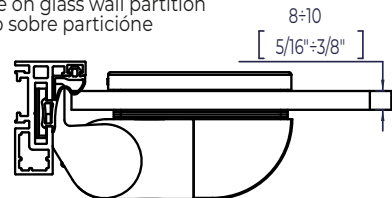

APPLICAZIONE SU 41AL
Application on 41AL
Aplicación con 41AL

Cod. 4CLXA

Applicazione vetro-muro
Glass to wall application
Aplicación vidrio-pared



Spessore vetro
Glass thickness
Espesor del vidrio
8 ÷ 12 mm
5/16 ÷ 15/32"

Portata
Weight
Peso
65 kg
145 Lbs



Indicata per saune
Suitable for saunas
Indicada para saunas







Indicata per docce
Suitable for showers
Indicada para duchas



Temperatura tollerabile
Temperature
Temperatura
-15° ÷ 100°C
5° ÷ 212°F

Finiture
Finishing
Acabados

-  611
-  620
-  630
-  665



! Piastrina standard
Standard plate
Plaqueta estándar

Applicazione vetro-muro
Glass to wall application
Aplicación vidrio-pared

Finiture
Finishing
Acabados



611



620



630



665

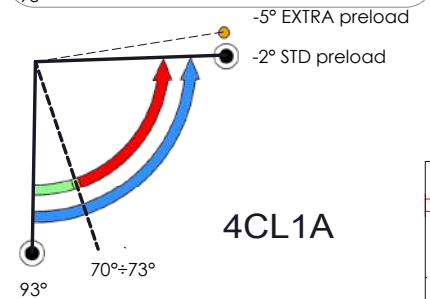
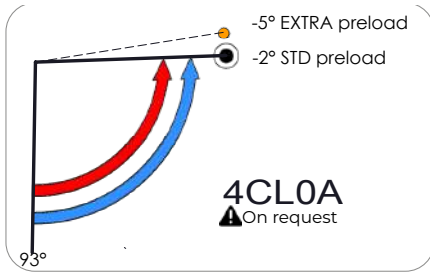

- █ possible door positions
- █ self-closing
- █ start closing
- █ free standing
- stop
- preload

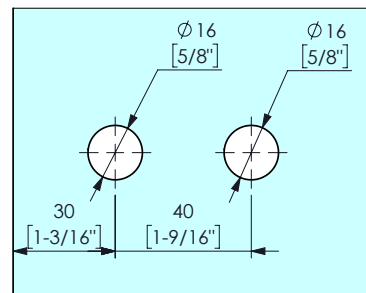
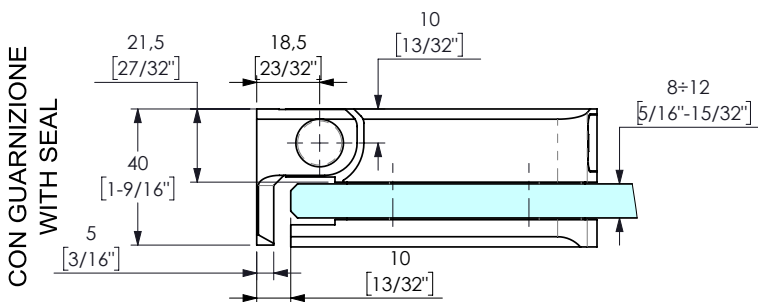
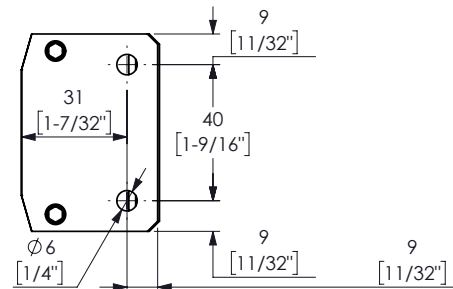
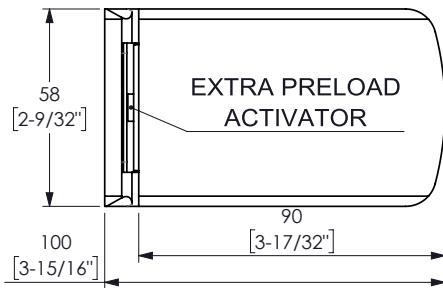
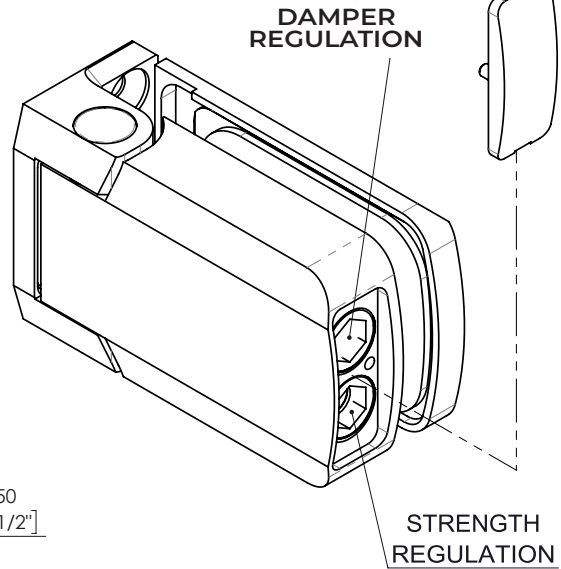
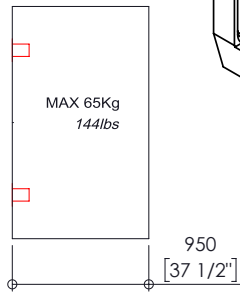

T4.35

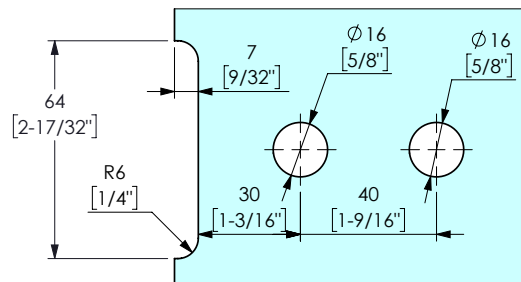
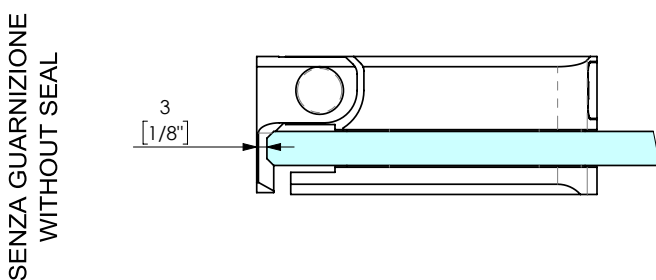

T4.36

Cod. 4CLXB

Applicazione vetro-muro o su profilo (41AL)
Glass to wall or profile (41AL) application
Aplicación vidrio-pared o con perfil (41AL)



Spessore vetro
Glass thickness
Espesor del vidrio
8 ÷ 12 mm
5/16 ÷ 15/32"



Portata
Weight
Peso
65 kg
145 Lbs



Indicata per saune
Suitable for saunas
Indicada para saunas



Indicata per docce
Suitable for showers
Indicada para duchas



Temperatura tollerabile
Temperature
Temperatura
-15°÷100°C
5°÷212°F

Finiture
Finishing
Acabados



611



620



630



665



! Piastrina corta per applicazione su profilo
Shorter plate for framed door application
Plaqueta mas corta para aplicaci3n en puertas con perfiles

Applicazione vetro-muro o su profilo (41AL)
Glass to wall or profile (41AL) application
Aplicaci3n vidrio-pared o con perfil (41AL)

- Finiture**
Finishing
Acabados
- 611
 - 620
 - 630
 - 665

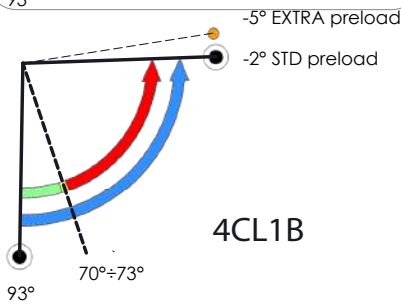
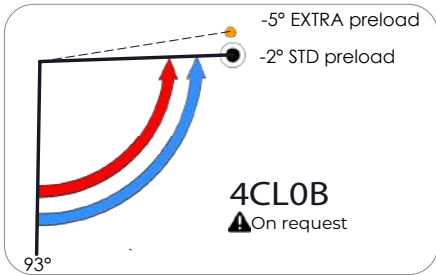

- █ possible door positions
- █ self-closing
- █ start closing
- █ free standing
- stop
- preload

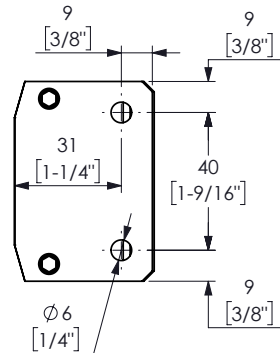
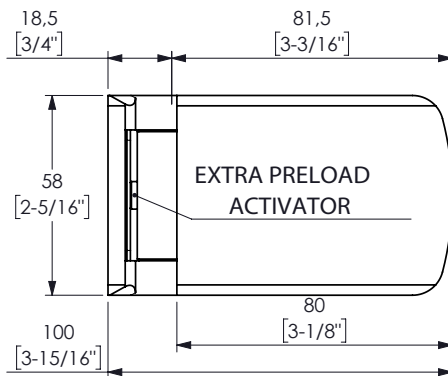
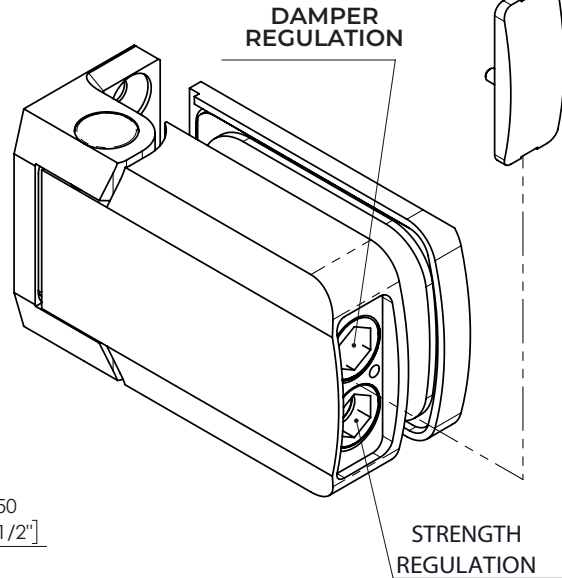
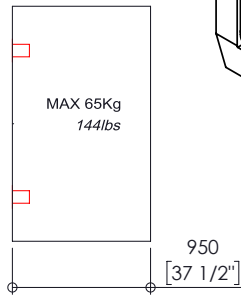

CON GUARNIZIONE
WITH SEAL

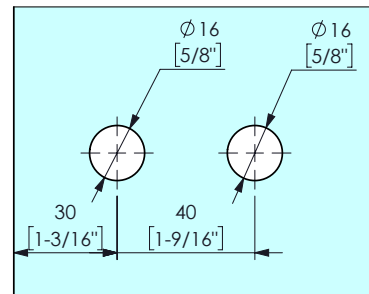
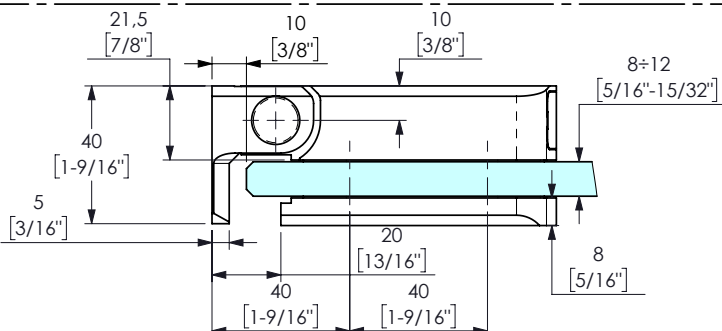

T4.35

SENZA GUARNIZIONE
WITHOUT SEAL

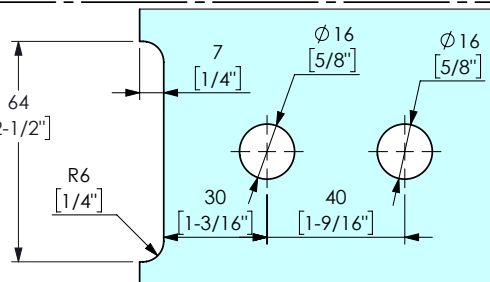
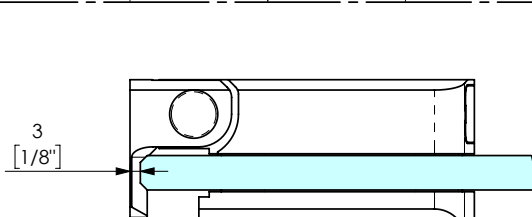

T4.36

Cod. 4CVXS

Applicazione vetro-vetro
Glass to glass application
Aplicación vidrio-vidrio



Spessore vetro
Glass thickness
Espesor del vidrio
8 ÷ 12 mm
5/16 ÷ 15/32"

Portata
Weight
Peso
65 kg
145 Lbs



Indicata per saune
Suitable for saunas
Indicada para saunas



Indicata per docce
Suitable for showers
Indicada para duchas



Temperatura tollerabile
Temperature
Temperatura
-15°÷100°C
5°÷212°F

Finiture
Finishing
Acabados



611



620



630



665



Finiture
Finishing
Acabados

611

620

630

665

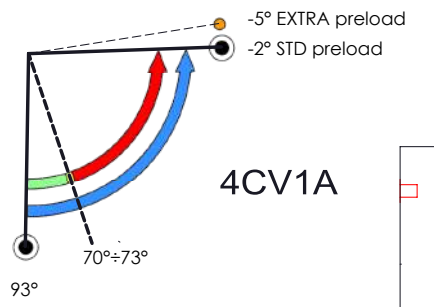
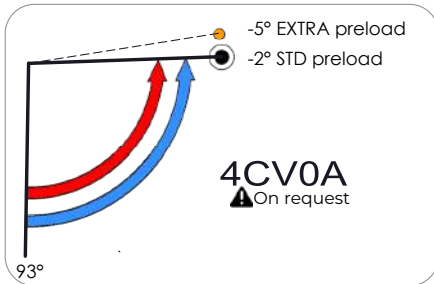

- possible door positions
- self-closing
- start closing
- free standing
- stop
- preload

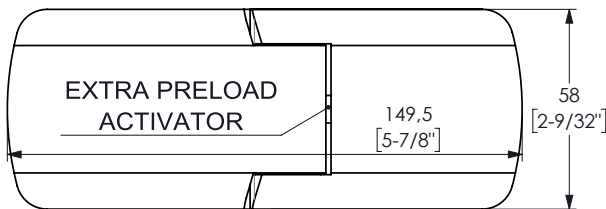
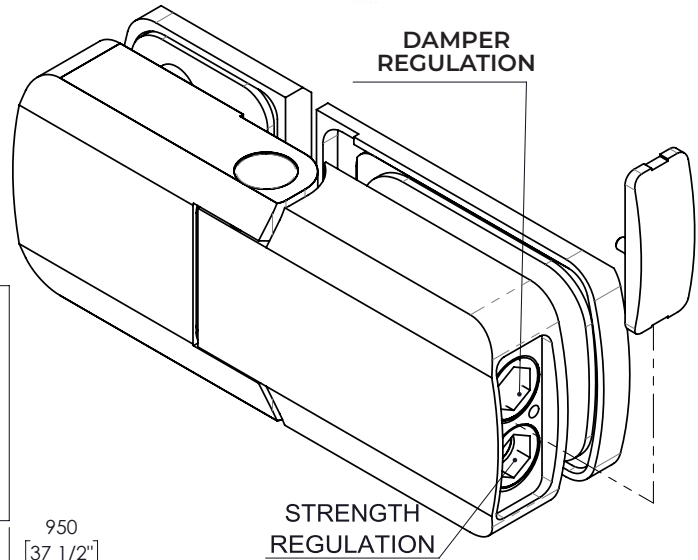
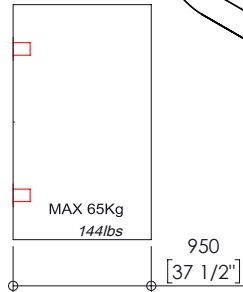

CON GUARNIZIONE
WITH SEAL

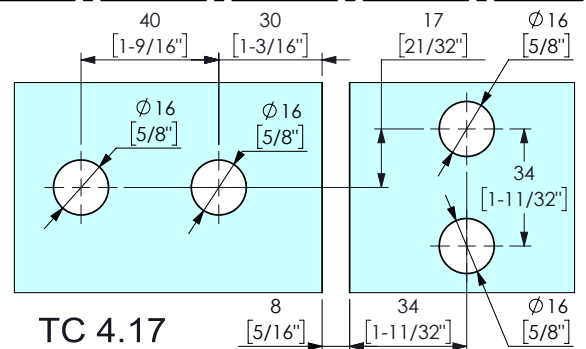
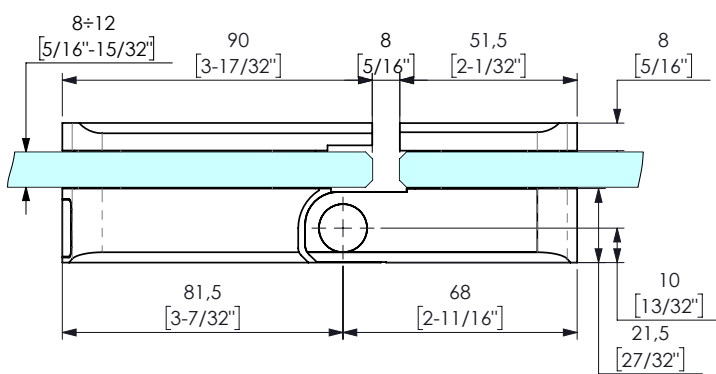

SENZA GUARNIZIONE
WITHOUT SEAL

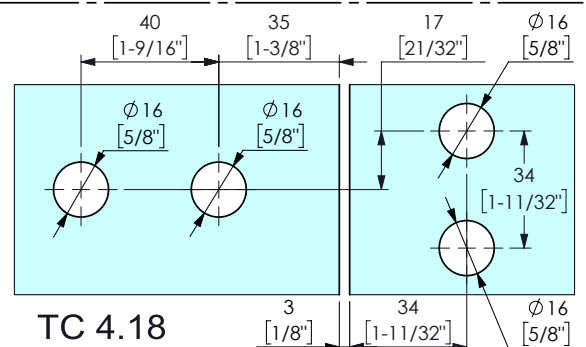
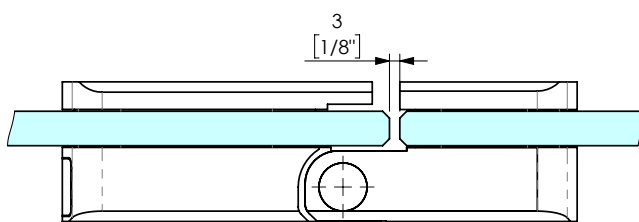

Cod. 4A0XR

Applicazione per porte con profilo o per porte in legno
In profile or wooden door application
Aplicación en puerta con perfiles y en puertas de madera



Applicazione per porte con profilo o per porte in legno
In profile or wooden door application
Aplicación en puerta con perfiles y en puertas de madera



Larghezza max dell'anta
Max door width
Ancho de la puerta
600 mm
23-5/8"



Peso max
Door weight
Peso máximo
40Kg
88Lbs



Testata
Tested
Testado
500.000 cicli
cycle - ciclos

Applicazioni Applications | Aplicaciones

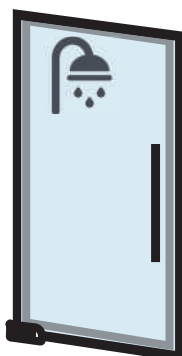

Profili doccia
Showers | Duchas

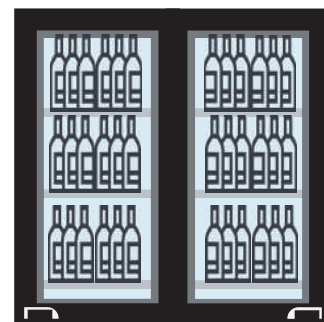

Frigoriferi
Fridge | Refrigerado

Cod. 4A01R-4A02R

Applicazione per porte con profilo
In profile door application
Aplicación en puerta con perfiles

- Possibile posizione della porta
Possible door position
Posible posición de la puerta
- Chiusura controllata
Self-closing
Cierre controlado
- Apertura controllata
Self-opening
Apertura controlada
- Posizione libera
Free standing
Posición libre
- Stop
- Stop esterno raccomandato
Recommended external stop
Stop exterior sugerido

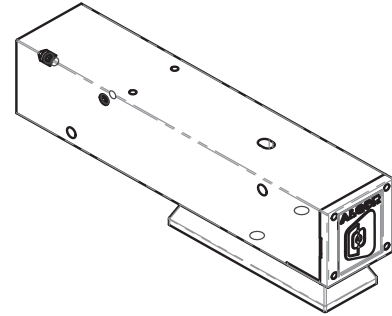
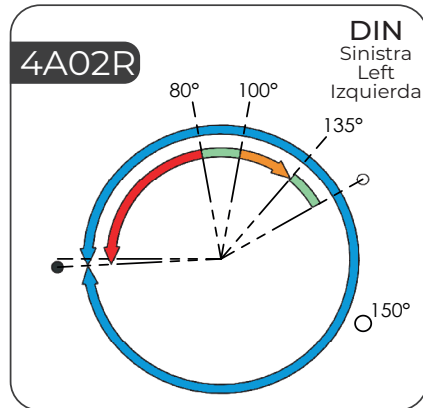
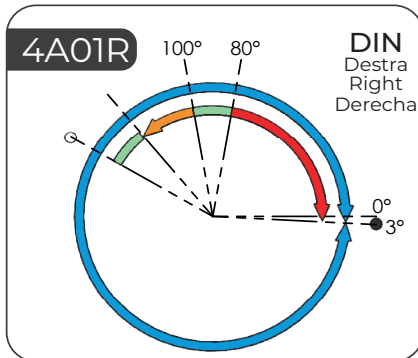
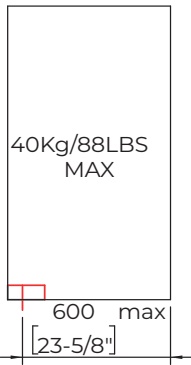

Range di regolazione della posizione
Position adjustment range
Rango de regulación de la posición

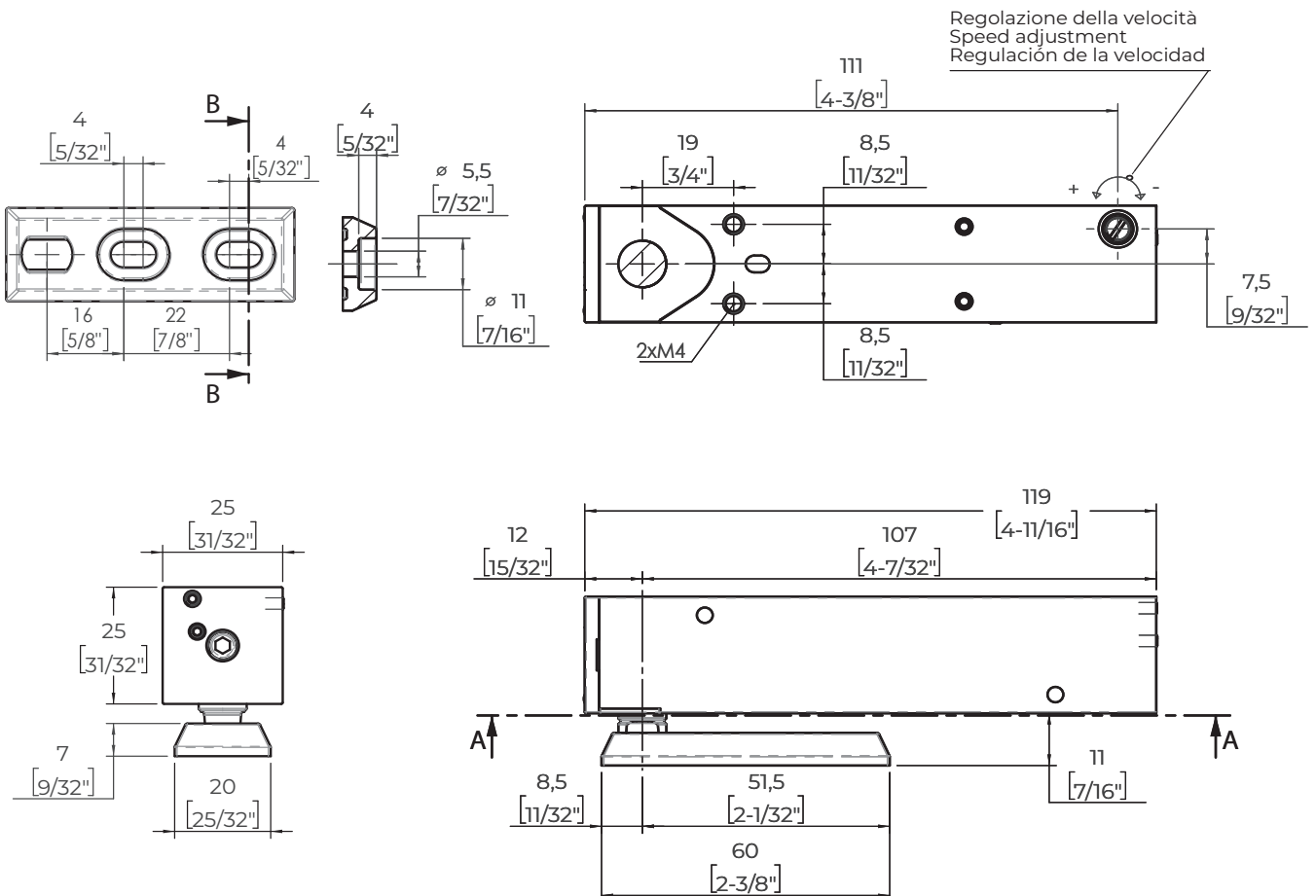
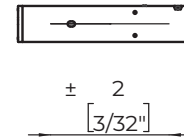

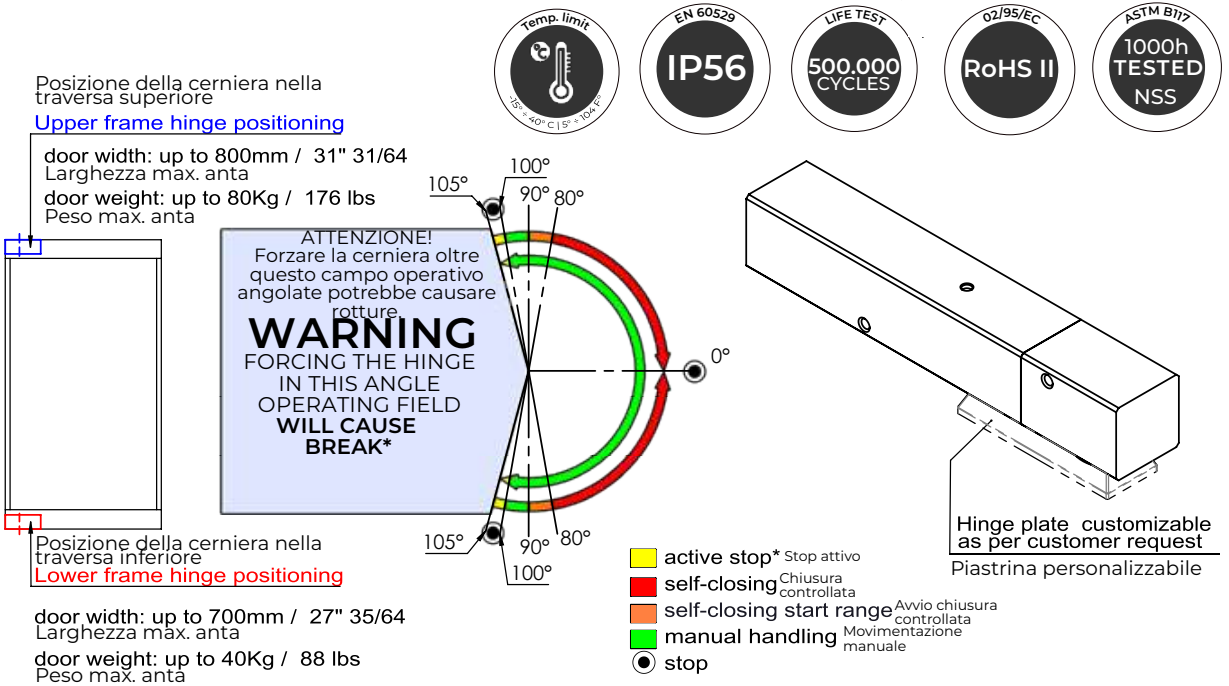

*Active stop force: **MAX 5kg [11lbs]** applied at 570mm [22" 7/16] from the door rotation axis
Forza stop attivo: max. 5 kg, applicati a 570 mm dall'asse di rotazione della porta

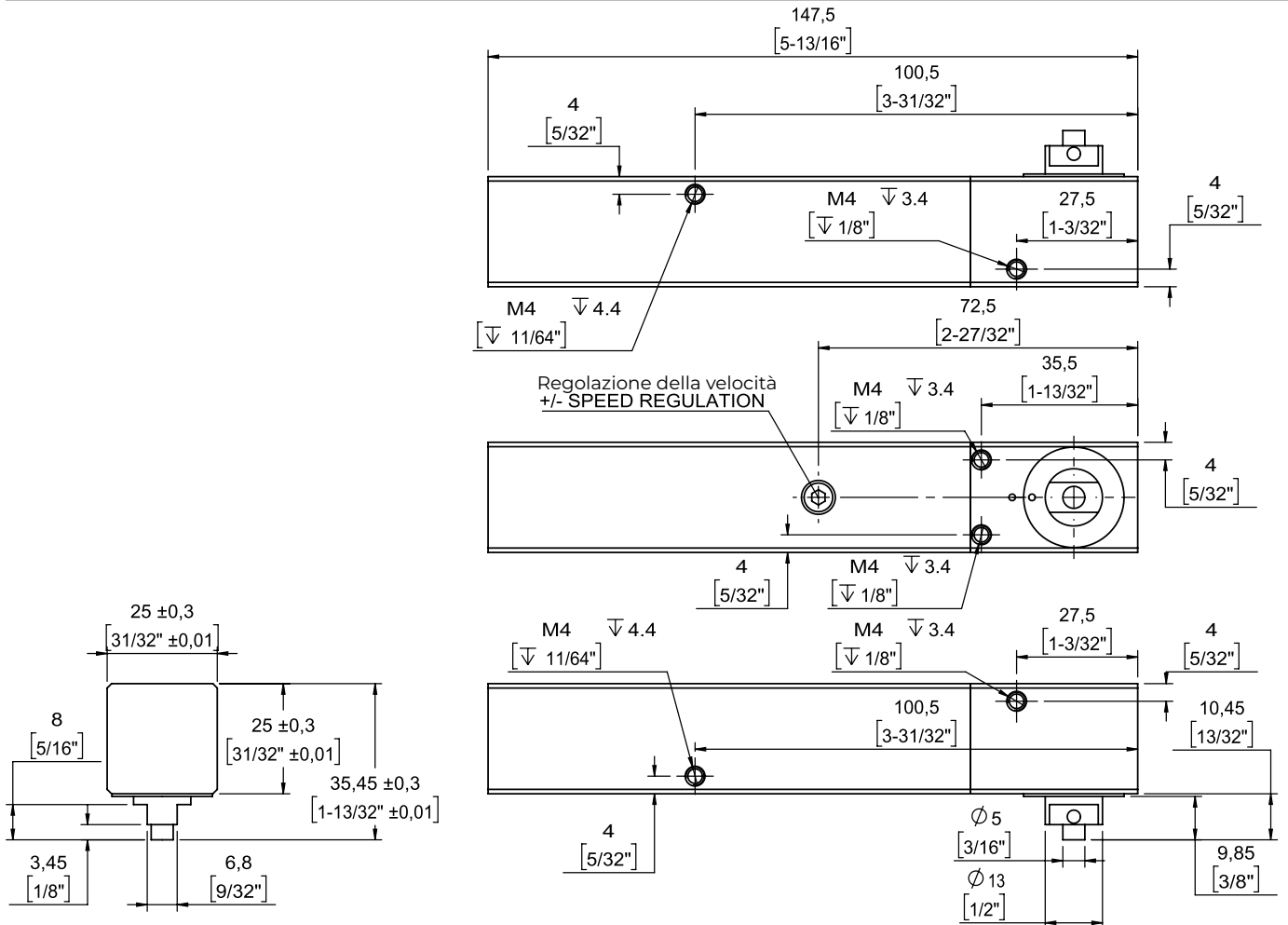

Cod. 4A04R

Applicazione per porte con profili docce
In shower profile door application
Aplicación en perfiles de duchas

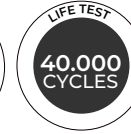
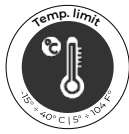

Posizione della cerniera nella traversa superiore

Upper frame hinge positioning

door width: up to 800mm / 31" 31/64
Larghezza max. anta
door weight: up to 80Kg / 176 lbs
Peso max. anta

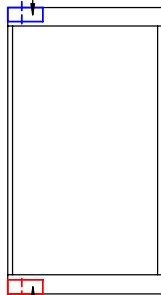

Posizione della cerniera nella traversa inferiore

Lower frame hinge positioning

door width: up to 700mm / 27" 35/64
Larghezza max. anta
door weight: up to 40Kg / 88 lbs
Peso max. anta

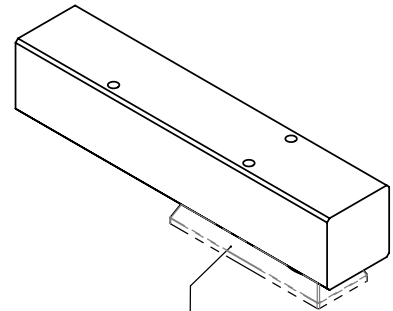
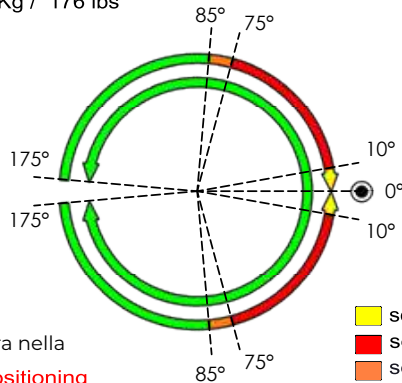

Piastrina personalizzabile
Hinge plate customizable
as per customer request

- soft close Stop attivo
- self-closing Chiusura controllata
- self-closing start range Avvio chiusura controllata
- manual handling Movimentazione manuale
- stop

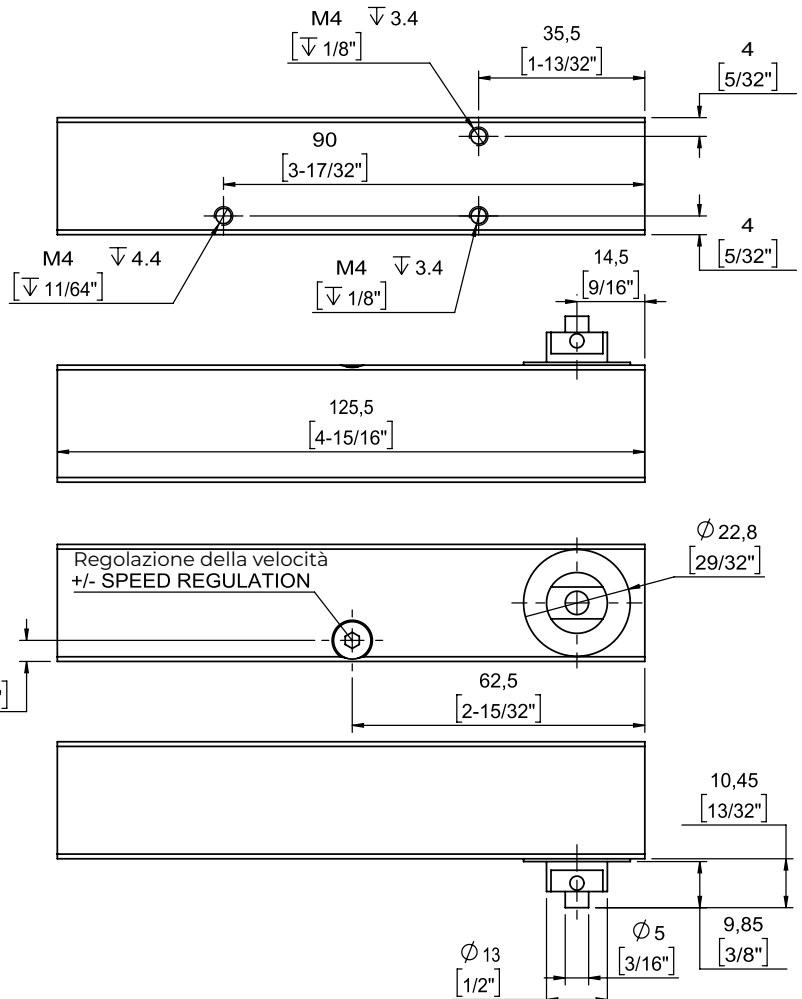

Caratteristiche e funzionalità Characteristics and operation Características y funciones	M25	M60	KS3000	M68	M68Z	SM68
Forze preconfigurate in fabbrica Factory preset strengths Fuerzas preconfiguradas en la fábrica	EN1154-2 Giallo Yellow Amarillo 120 kg 264,55 Lbs	EN1154-2 Giallo Yellow Amarillo 160 kg 352,74 Lbs	EN1154-2 Giallo Yellow Amarillo 120 kg 264,55 Lbs			
	EN1154-3 Rosso Red Rojo 120 kg 264,55 Lbs	EN1154-3 Rosso Red Rojo 160 kg 352,74 Lbs	EN1154-3 Rosso Red Rojo 120 kg 264,55 Lbs	EN1154-3 Rosso Red Rojo 100 kg 220,46 Lbs	EN1154-3 Rosso Red Rojo 100 kg 220,46 Lbs	EN1154-3 Rosso Red Rojo 100 kg 220,46 Lbs
	EN1154-4/5 Nero Black Negro 200 kg 440,92 Lbs					
Forza per disabili Strength for disabled Fuerza para minusválidos	Su richiesta Upon request Bajo pedido	Su richiesta Upon request Bajo pedido	Su richiesta Upon request Bajo pedido			
Heavy duty Heavy duty Heavy duty	Su richiesta 350 kg Upon request 350 kg Bajo pedido 350 kg					
Ambienti aggressivi Aggressive environments Ambientes corrosivos	Su richiesta Upon request Bajo pedido	Su richiesta Upon request Bajo pedido	Su richiesta Upon request Bajo pedido			
Larghezza max porta Max width door Ancho max de la puerta	1100 mm 43 5/16"	1100 mm 43 5/16"	1100 mm 43 5/16"	950 mm 37 13/32"	950 mm 37 13/32"	950 mm 37 13/32"
Peso della porta Max door weight Peso de la puerta	120 kg 264,55 Lbs	160 kg 352,74 Lbs	120 kg 264,55 Lbs	100 kg 220,46 Lbs	100 kg 220,46 Lbs	100 kg 220,46 Lbs
Termocostanza Thermo constancy Termocostancia	Su richiesta Upon request Bajo pedido	✔	✔			
Blocco corsa e indurimento meccanico Block stop & Back check Bloqueo de la carrera y endurecimiento mecánico	Su richiesta Upon request Bajo pedido			120°	120°	120°
Teste di perno intercambiabili Interchangeable spindle heads Cabezas de pernio intercambiables	Su richiesta Upon request Bajo pedido	Su richiesta Upon request Bajo pedido	Su richiesta Upon request Bajo pedido			✔
Teste di perno prolungate Extended spindle heads Cabezas de pernio alargadas	Su richiesta Upon request Bajo pedido	Su richiesta Upon request Bajo pedido	Su richiesta Upon request Bajo pedido			Su richiesta Upon request Bajo pedido
Coperchio con fissaggio Cover fixed to Tapadera con fijado	Cassetta a cementare Cement case Caja a cementar	Cassetta a cementare Cement case Caja a cementar	Corpo del chiudiporta Door closer body Cuerpo del cierrapuerta	Cassetta a cementare Cement case Caja a cementar	Corpo del chiudiporta Door closer body Cuerpo del cierrapuerta	Cassetta a cementare Cement case Caja a cementar
Lunghezza della cassetta a cementare Cement case length Largo de la caja a cementar	283 mm 11 9/64"	267 mm 10 33/64"	270 mm 10 5/8"	280 mm 11 1/32"	275 mm 10 53/64"	275 mm 10 53/64"
Larghezza della cassetta a cementare Cement case width Ancho de la caja a cementar	130 mm 5 1/8"	96 mm 3 25/32"	80 mm 3 5/32"	110 mm 4 21/64"	108 mm 4 1/4"	108 mm 4 1/4"
Altezza cassetta a cementare Cement case height Altura de la caja a cementar	65 mm 2 9/16"	56 mm 2 13/64"	56 mm 2 13/64"	43 mm 1 11/16"	41 mm 1 39/64"	43 mm 1 11/16"

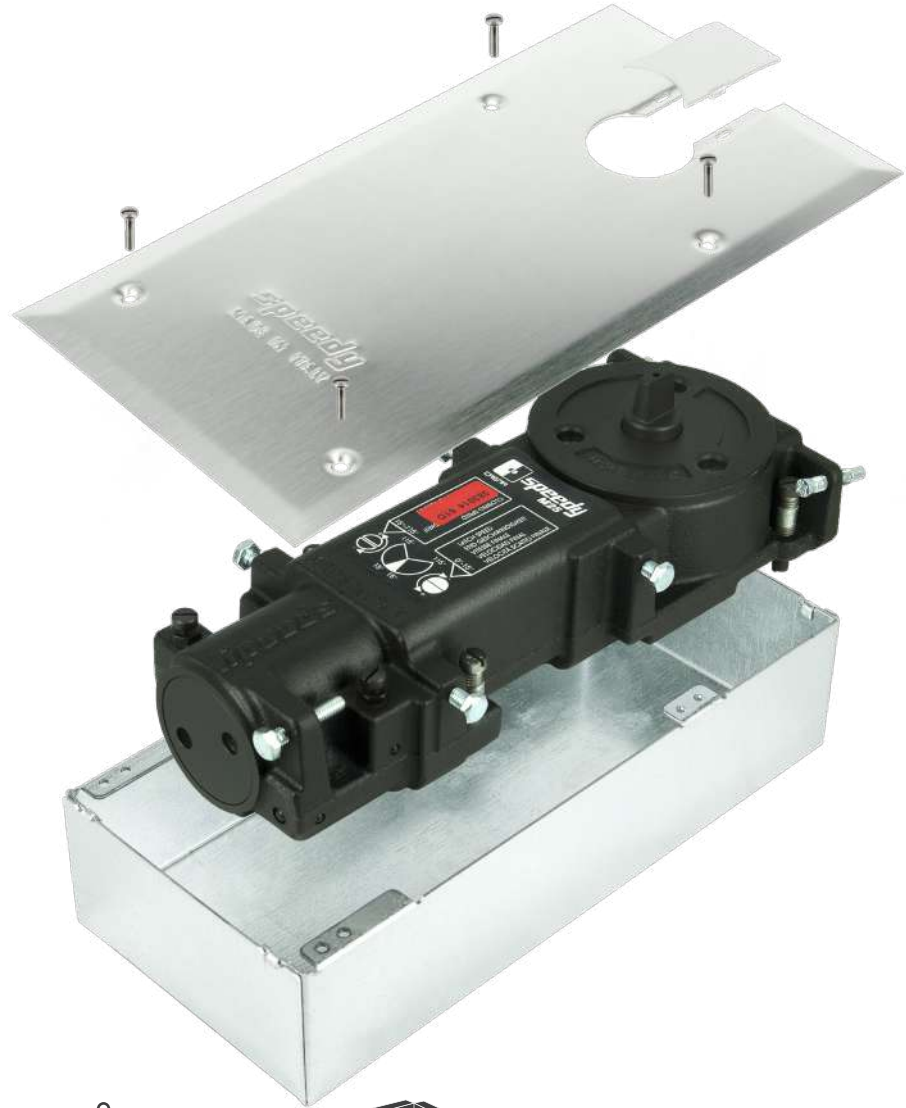
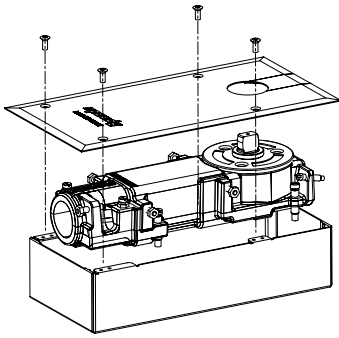

Finiture Standard
Standard finishes
Acabados estándar



Finiture su richiesta
Finishes upon request
Acabados bajo pedido

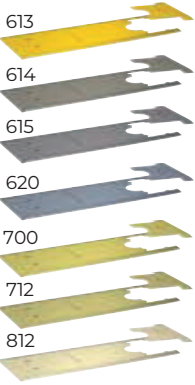

Larghezza max dell'anta
Max door width
Ancho máximo de la puerta

75 ÷ 140 cm
29 17/32 ÷ 55 1/8"



Peso max
Door weight
Peso máximo

200 kg
440,92 Lbs



Peso della confezione
Packaging weight
Peso de la confección

6,4 kg
14,10 Lbs



Dimensioni della cassetta
a cementare
Dim. of cement case
Dim. de la caja a cementar

130x283x65 mm
5 1/8"x11 9/64"x25 19/32"

Larghezza massima porta Maximum door width Ancho máximo de la puerta	Esterni Exterior Externos	Interni Interior Internos
Forza gialla Yellow Strength Fuerza amarilla	75 cm 29 17/32"	85 cm 33 15/32"
Forza rossa Red Strength Fuerza roja	100 cm 39 3/8"	110 cm 43 5/16"
Forza nera Black Strength Fuerza negra	110 cm 43 5/16"	140 cm 55 1/8"

A richiesta | Upon request | Bajo pedido

- ✓ Esecuzione speciale per porte fino a 350 kg
Special execution for doors up to 350 kg
Ejecuciones especiales para puertas de hasta 350 kg de peso bajo pedido
- ✓ Blocco corsa e indurimento meccanico a partire da 70°
Back stop and back check from 70° upon request
posibilidad de bloque de la carrera y endurecimiento a partir de 70°
- ✓ Versione con teste di perno intercambiabili
Version with interchangeable spindle head upon request
Disponibile con pernio intercambiabile
- ✓ Versione con perno prolungato
Version with extended spindle
Se puede elevar el pernio
- ✓ Termocostanza
Thermo costancy available upon request
Termocostancia si se solicita bajo pedido

Calibri perni | Spindle caliber gauge | Indicadores de los pernios

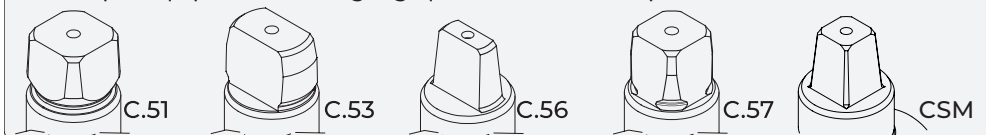

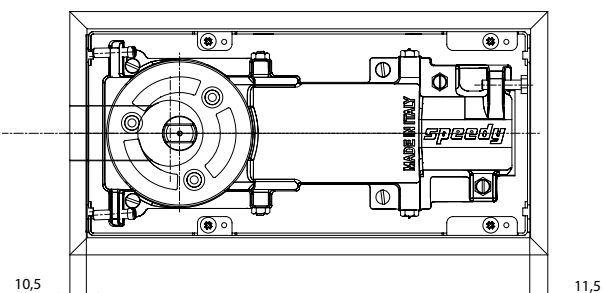
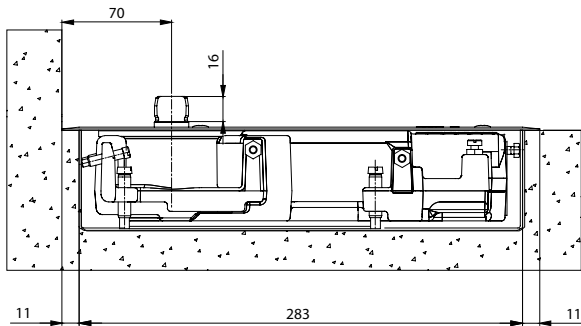
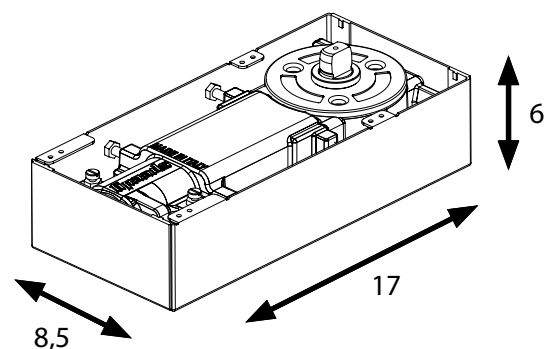
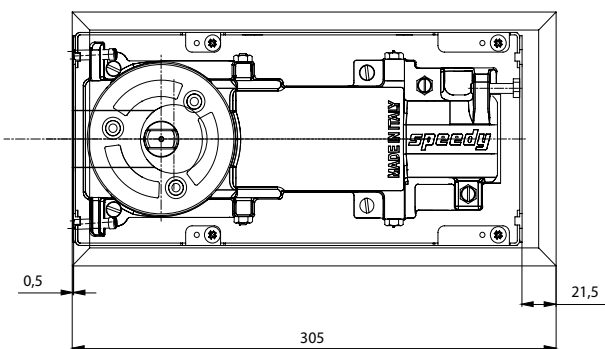
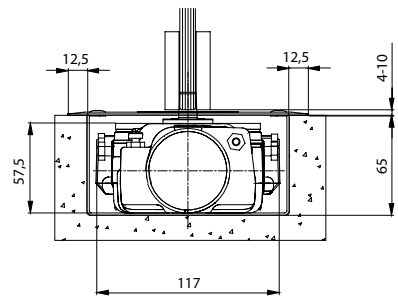
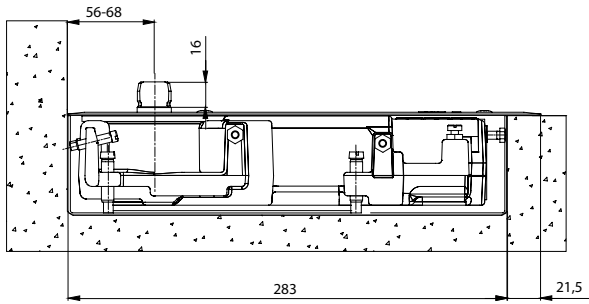
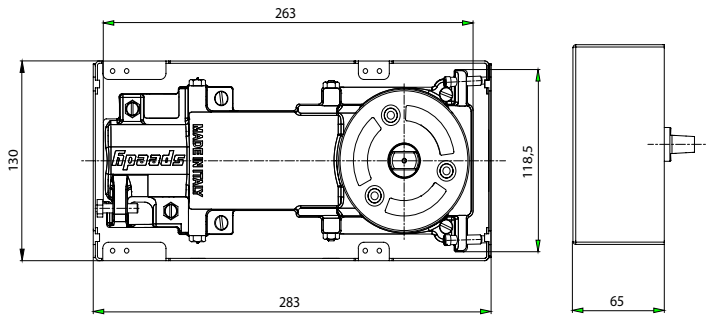
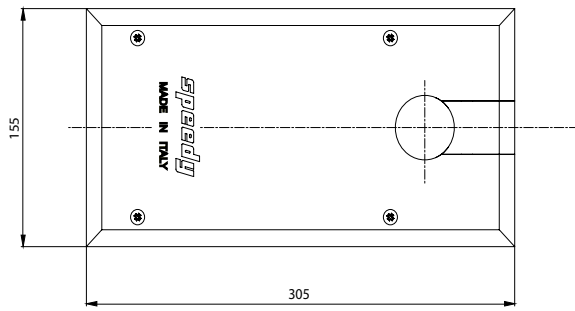

● FERMO COSTANTE
Costant hold-open
Retención constante

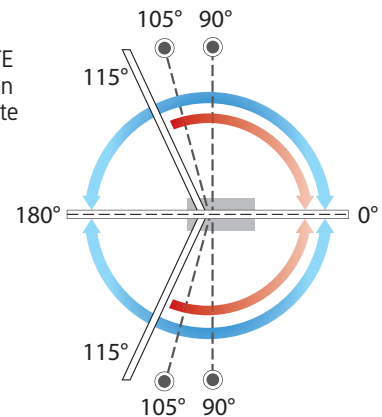

EN 1154 - 4	MAX 200 KG
EN 1154 - 3	
EN 1154 - 2	
EN 1154 - 1	
MAX	120 KG
750	
750-850	
850-1100	
1100-1400	

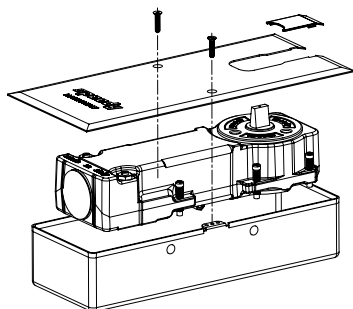

Finiture Standard
Standard finishes
Acabados estándar

611

800

Finiture su richiesta
Finishes upon request
Acabados bajo pedido

613

614

615

620

700

712

812



Larghezza max dell'anta
Max door width
Ancho máximo de la puerta

75 ÷ 110 cm
29 17/32 ÷ 55 1/8"



Peso max
Door weight
Peso máximo

160 kg
264,5 Lbs



Peso della confezione
Packaging weight
Peso de la confezione

5,1 kg
11,24 Lbs



Dimensioni della cassetta
a cementare
Dim. of cement case
Dim. de la caja a cementar

96,5x267x56 mm
3 25/32"x10 33/64"x2 13/64"

Incluso | Included | Incluido

- ✓ Termocostanza di serie
Thermo costancy as standard
Termocostancia de serie

A richiesta | Upon request | Bajo pedido

- ✓ Versione con teste di perno intercambiabili
Version with interchangeable spindle head upon request
Disponibile con pernio intercambiabile
- ✓ Versione con perno prolungato
Version with extended spindle
Se puede elevar el pernio
- ✓ Versione speciale con cassetta, dispositivi di bloccaggio e viti di regolazione in acciaio inox per ambienti aggressivi
Special version with stainless steel cement case, blocking system and regulation screws suitable for aggressive installation
Versión especial con caja, sistemas de fijación y tornillos de regulación en acero inox para instalaciones en ambientes corrosivos

Larghezza massima porta Maximum door width Ancho máximo de la puerta	Esterni Exterior Externos	Interni Interior Internos
Forza gialla Yellow Strength Fuerza amarilla	75 cm 29 17/32"	85 cm 33 15/32"
Forza rossa Red Strength Fuerza roja	100 cm 39 3/8"	110 cm 43 5/16"

Calibri perni | Spindle caliber gauge | Indicadores de los pernios

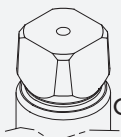

C.51

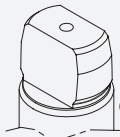

C.53

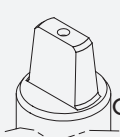

C.56

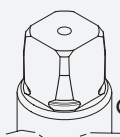

C.57

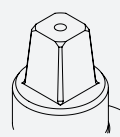

CSM

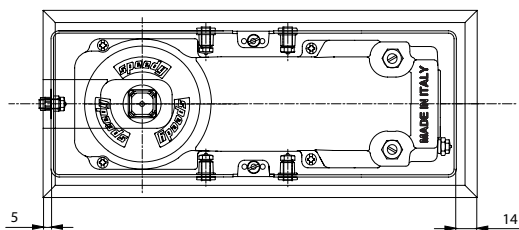
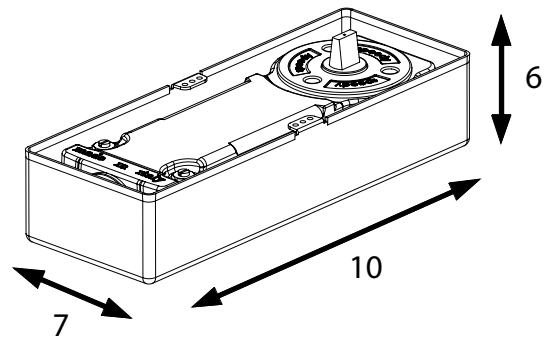
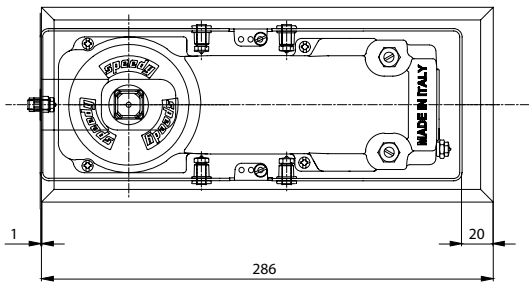
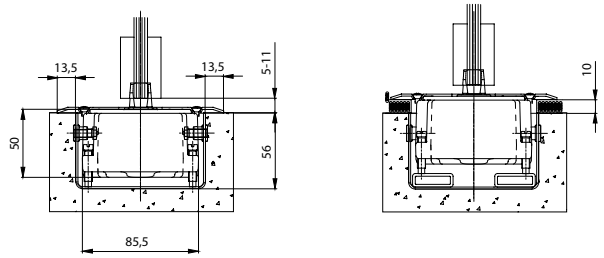
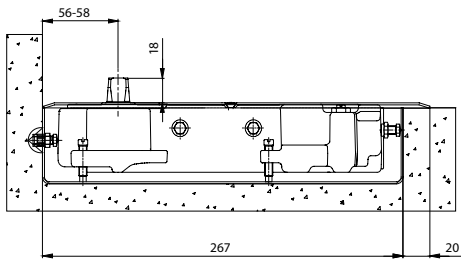
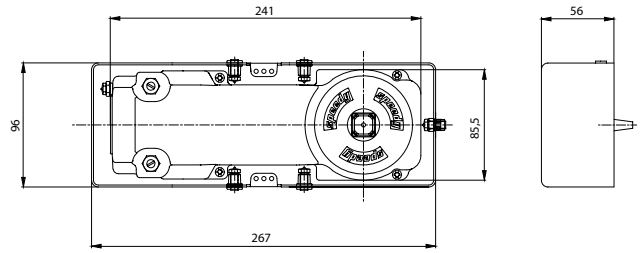
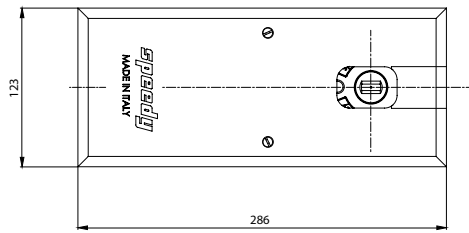

● FERMO COSTANTE
Constant hold-open
Retención constante

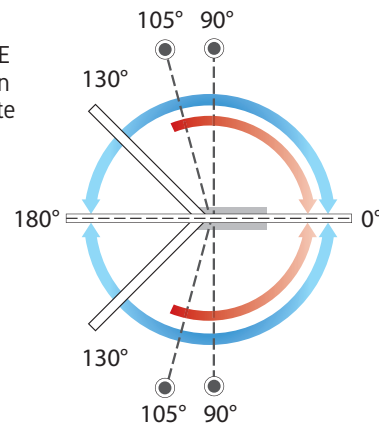

EN 1154 - 3
EN 1154 - 2
EN 1154 - 1
MAX 160 KG
750
750-1000
950-1150

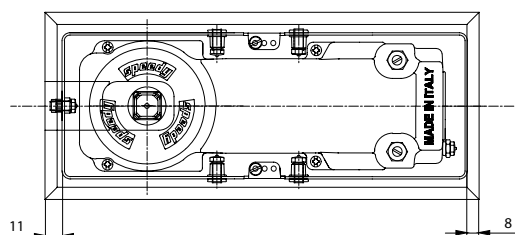

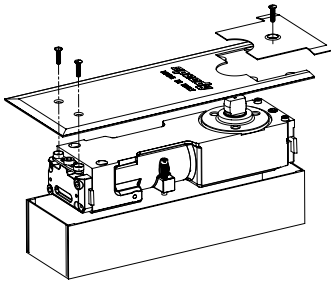

Finiture Standard
Standard finishes
Acabados estándar

611

800

Finiture su richiesta
Finishes upon request
Acabados bajo pedido

613

614

615

620

700

712

812



Fissaggio ultra-rapido ed efficace della cassetta a cementare
Quick and effective fixing in the cement case
Fijación ultra rápida y eficaz de la caja a cementar



Larghezza max dell'anta
Max door width
Ancho máximo de la puerta
75 ÷ 110 cm
29 17/32 ÷ 43 5/16"



Peso max Door weight
Peso máximo
120 kg
264,55



Peso della confezione
Packaging weight
Peso de la confezione
4,3 kg
9,47 Lbs



Dimensioni della cassetta a cementare
Dim. of cement case
Dim. de la caja a cementar
80x270x56 mm
3 5/32"x10 5/8"x2 13/64"

Larghezza massima porta Maximum door width Ancho máximo de la puerta	Esterni Exterior Externos	Interni Interior Internos
Forza gialla Yellow Strength Fuerza amarilla	75 cm 29 17/32"	85 cm 33 15/32"
Forza rossa Red Strength Fuerza roja	100 cm 39 3/8"	110 cm 43 5/16"

A richiesta | Upon request | Bajo pedido

- ✓ **Versione con teste di perno intercambiabili**
Version with interchangeable spindle head upon request
Disponibile con pernio intercambiabile
- ✓ **Versione con perno prolungato**
Version with extended spindle
Se puede elevar el pernio

Calibri perni | Spindle caliber gauge | Indicadores de los pernios



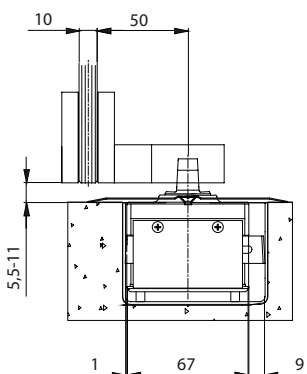
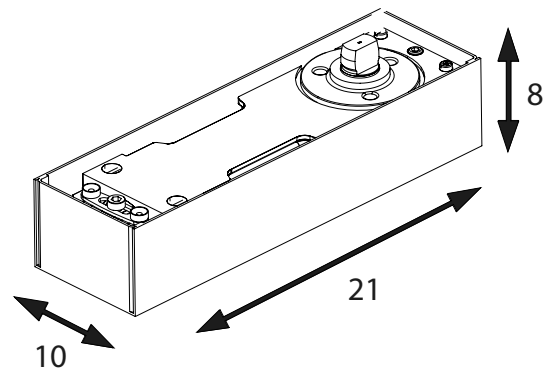
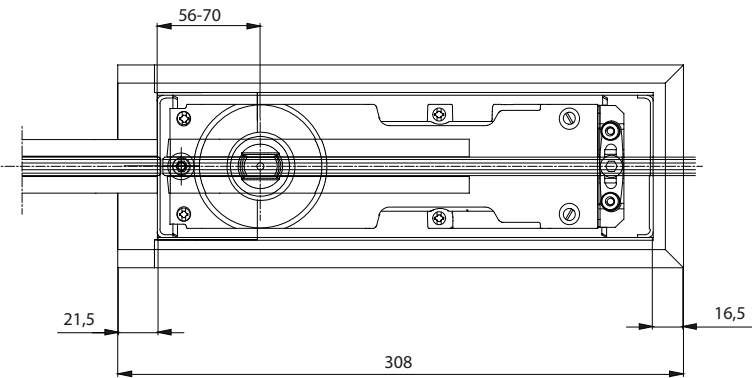
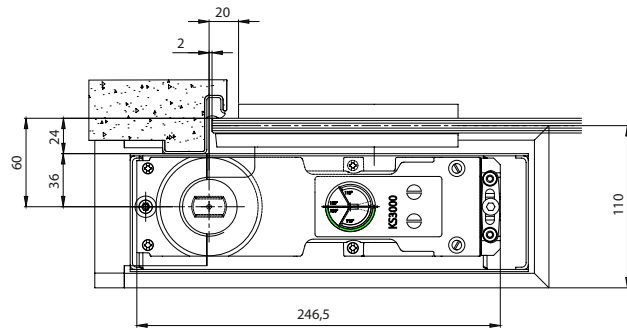
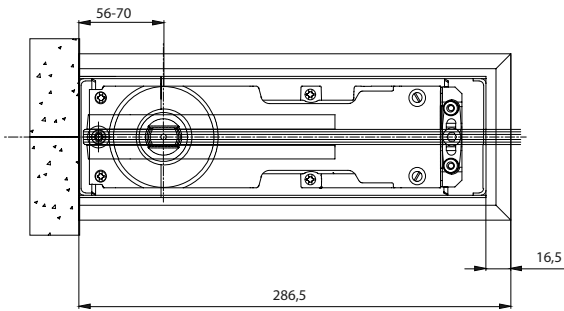
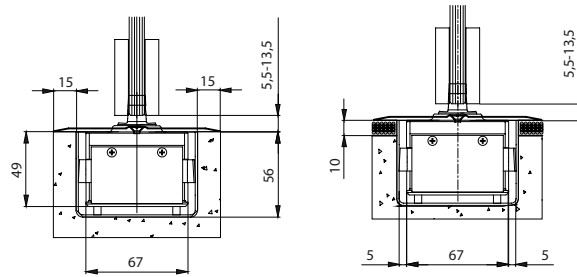
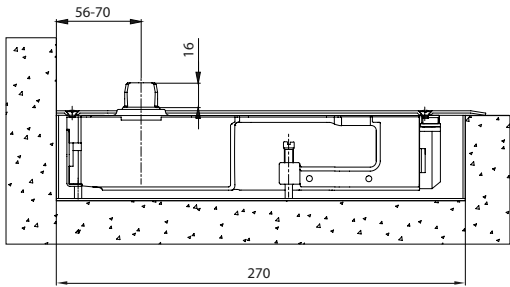
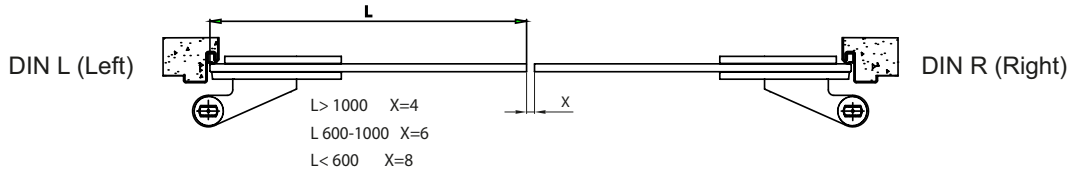
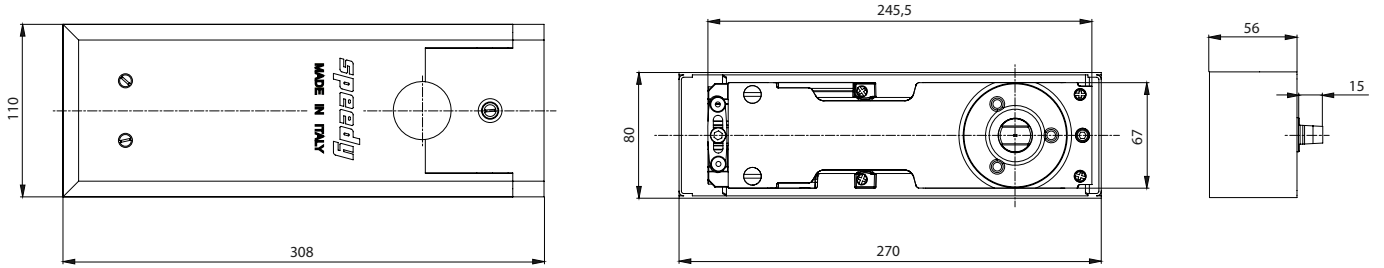

● FERMO COSTANTE
Costant hold-open
Retención constante

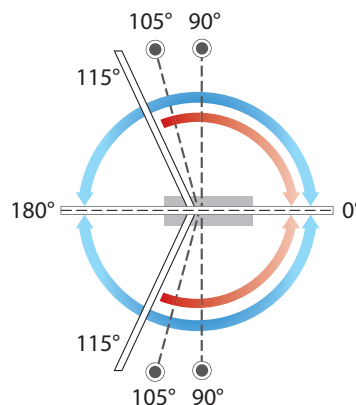

EN 1154 - 3
EN 1154 - 2
EN 1154 - 1
MAX 120 KG
750
750-850
950-1100

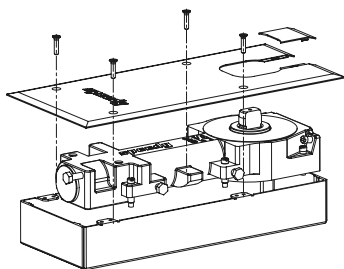

Finiture Standard
Standard finishes
Acabados estándar

800



Larghezza max dell'anta
Max door width
Ancho máximo de la puerta

85 ÷ 95 cm
33 15/32" ÷ 37 13/32"



Peso max
Door weight
Peso máximo

100 kg
220,46 Lbs



Peso della confezione
Packaging weight
Peso de la confezione

5 kg
11,02 Lbs



Dimensioni della cassetta
a cementare
Dim. of cement case
Dim. de la caja a cementar
110x280x43 mm
42 1/64" x 110 15/64" x 1 11/16"

Larghezza massima por ta Maximum door width Ancho máximo de la puerta	Esterni Exterior Externos	Interni Interior Internos
Forza rossa Red Strength Fuerza roja	85 cm 33 15/32"	95 cm 37 13/32"

Calibri perni | Spindle caliber gauge | Indicadores de los pernios

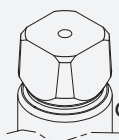

C.51

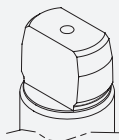

C.53

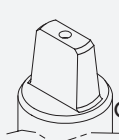

C.56

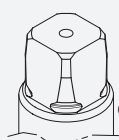

C.57

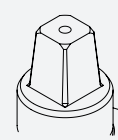

CSM

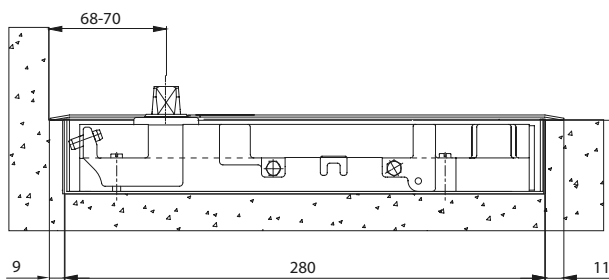
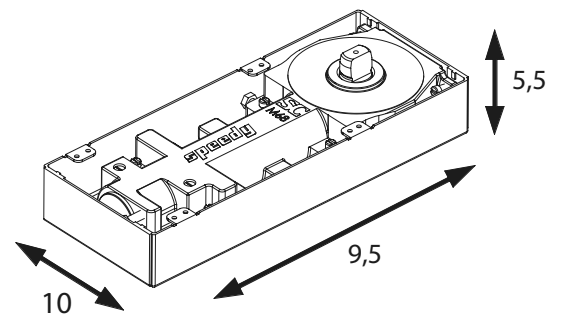
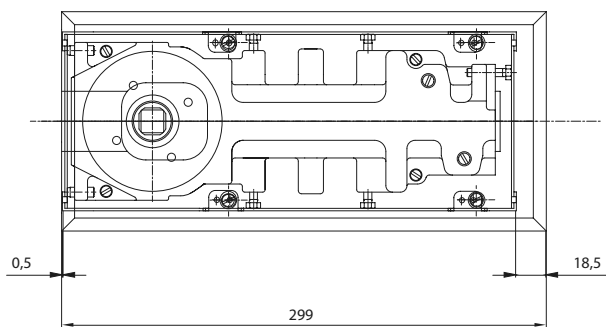
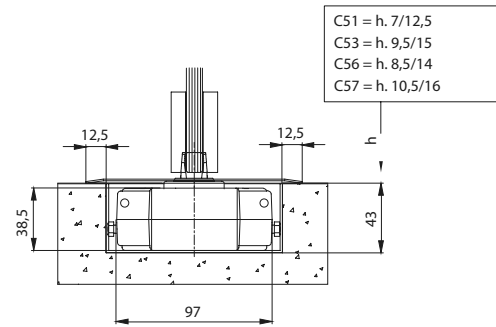
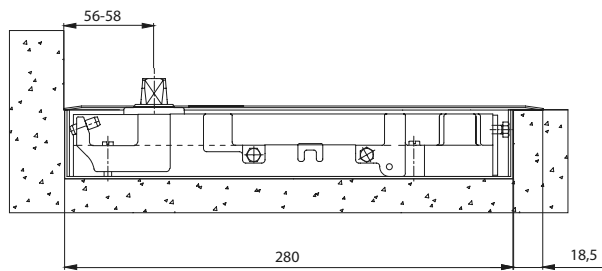
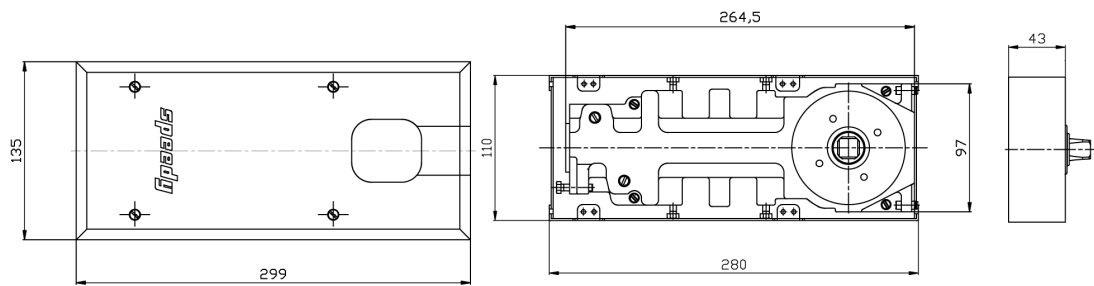

● FERMO COSTANTE
Costant hold-open
Retención constante

● BACK-STOP A 120°
BACK-STOP 120°
BACK-STOP A 120°

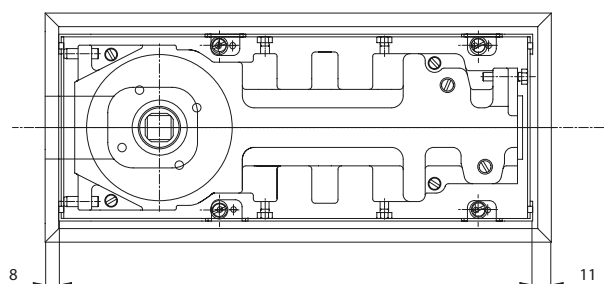
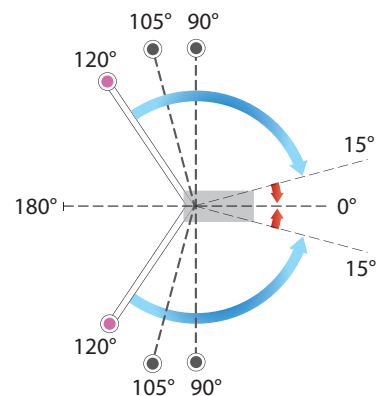

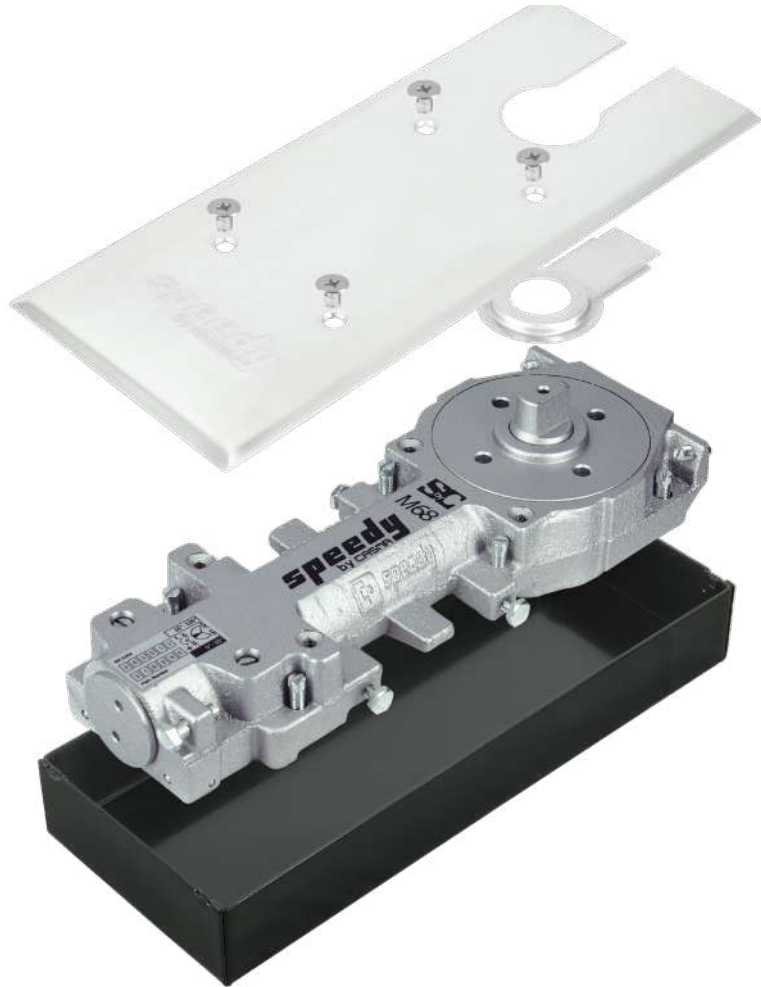
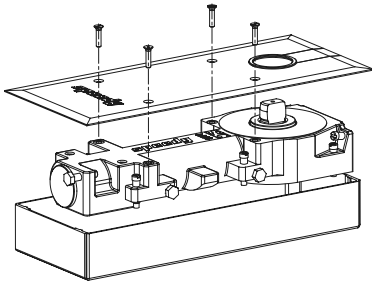

Finiture Standard
Standard finishes
Acabados estándar

800



Larghezza max dell'anta
Max door width
Ancho máximo de la puerta

75 ÷ 85 cm
29 17/32" ÷ 33 15/32"



Peso max
Door weight
Peso máximo

100 kg
220,46 Lbs



Peso della confezione
Packaging weight
Peso de la confección

5 kg
11,02 Lbs



Dimensioni della cassetta
a cementare
Dim. of cement case
Dim. de la caja a cementar

108x275x41 mm
3 15/16" x 10 53/64" x 1 39/64"

Larghezza massima porta Maximum door width Ancho máximo de la puerta	Esterni Exterior Externos	Interni Interior Internos
Forza rossa Red Strength Fuerza roja	85 cm 33 15/32"	95 cm 37 13/32"

Calibri perni | Spindle caliber gauge | Indicadores de los pernios

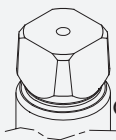

C.51

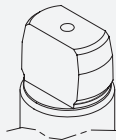

C.53

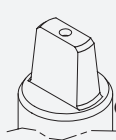

C.56

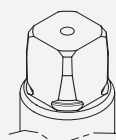

C.57

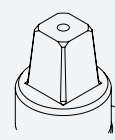

CSM

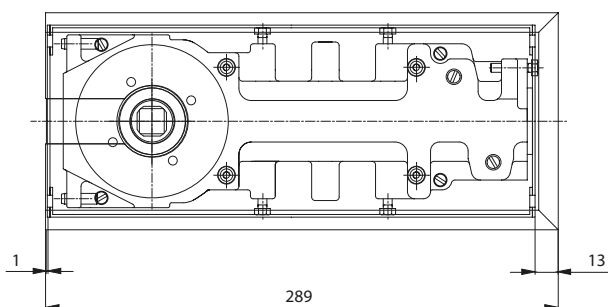
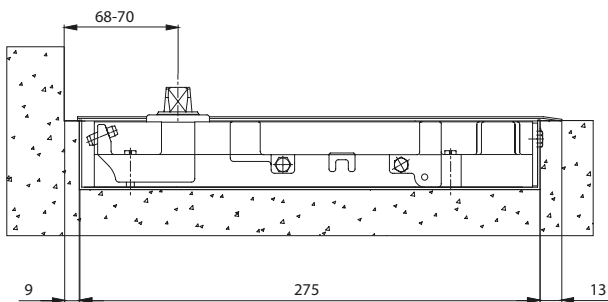
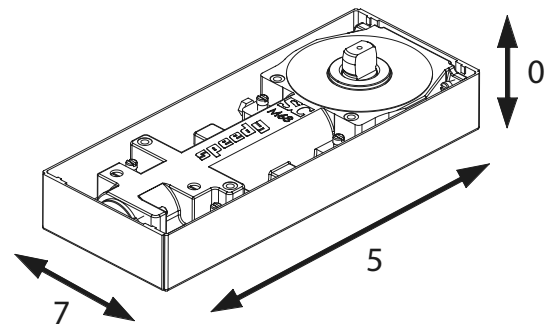
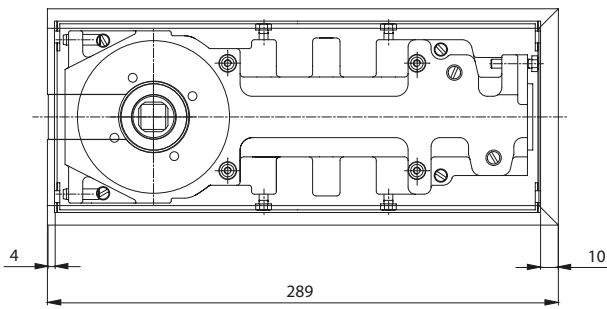
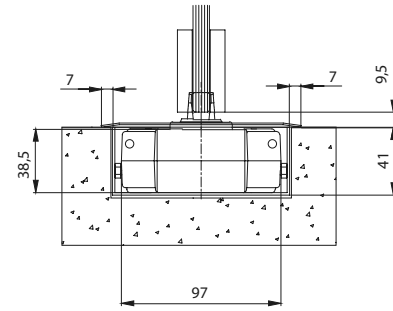
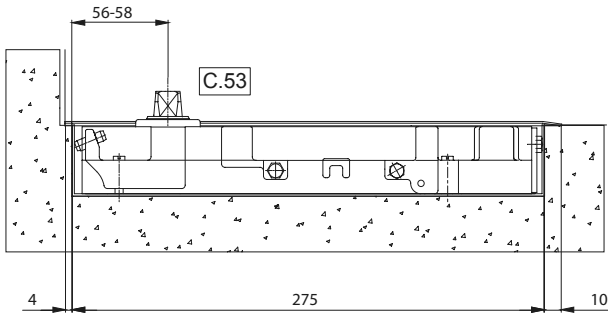
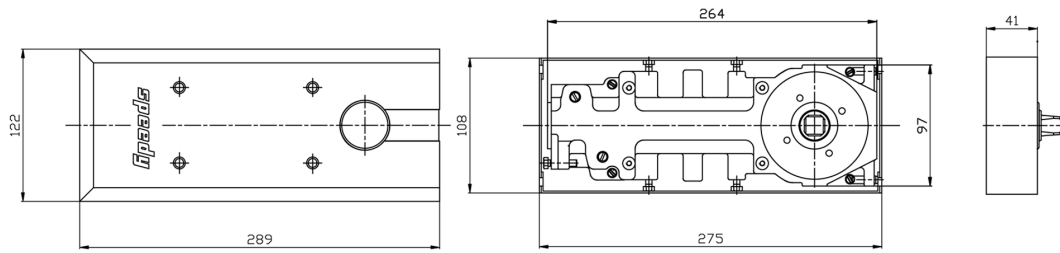

● FERMO COSTANTE
Costant hold-open
Retención constante

● BACK-STOP A 120°
BACK-STOP 120°
BACK-STOP A 120°

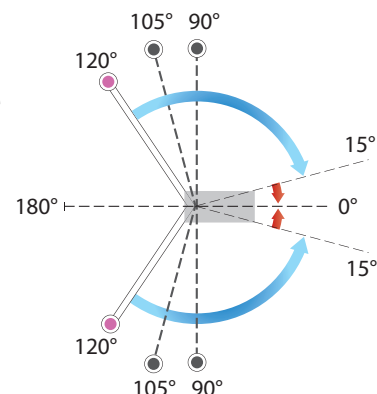

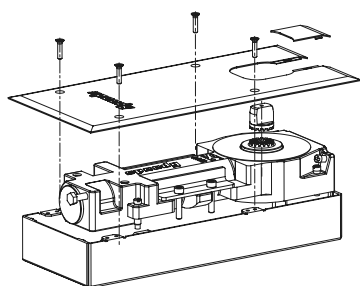

Finiture Standard
Standard finishes
Acabados estándar

800



Larghezza max dell'anta
Max door width
Ancho máximo de la puerta

85 ÷ 95 cm
33 15/32" ÷ 37 13/32"



Peso max
Door weight
Peso máximo

100 kg
220,46 Lbs



Peso della confezione
Packaging weight
Peso de la confección

5 kg
11,02 Lbs



Dimensioni della cassetta
a cementare
Dim. of cement case
Dim. de la caja a cementar

110x280x43 mm
42 1/64" x 110 15/64" x 1 11/16"

Larghezza massima porta Maximum door width Ancho máximo de la puerta	Esterni Exterior Externos	Interni Interior Internos
Forza rossa Red Strength Fuerza roja	85 cm 33 15/32"	95 cm 37 13/32"

Calibri perni | Spindle caliber gauge | Indicadores de los pernios

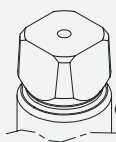

C.51

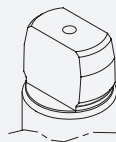

C.53

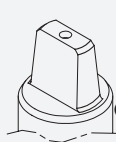

C.56

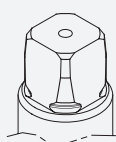

C.57

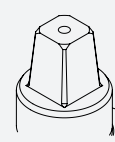

CSM

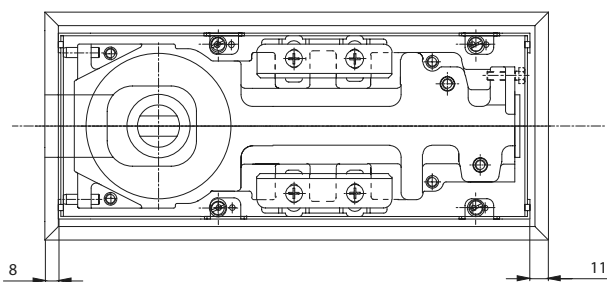
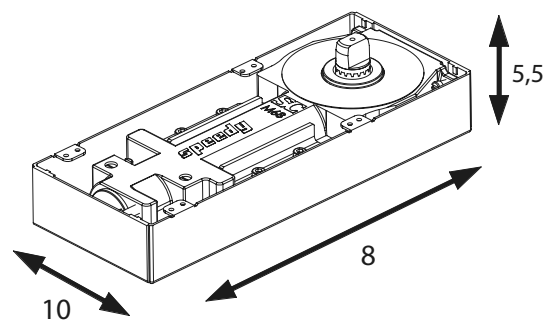
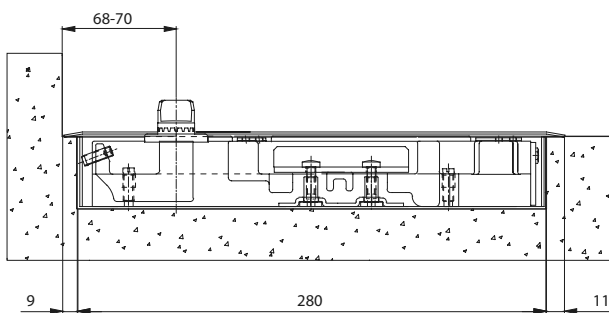
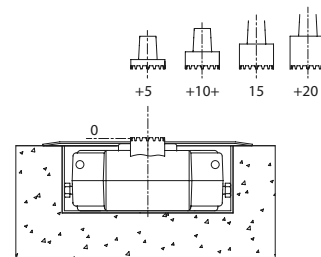
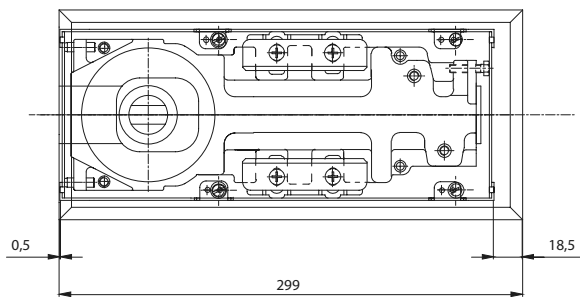
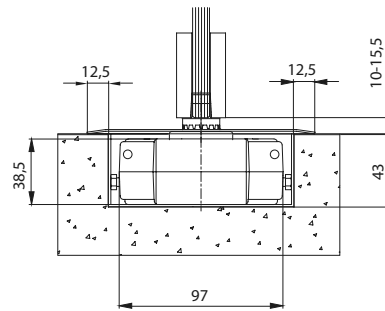
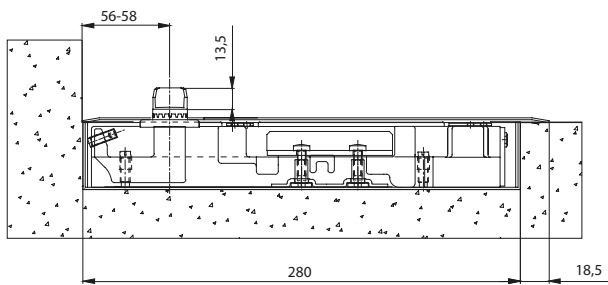
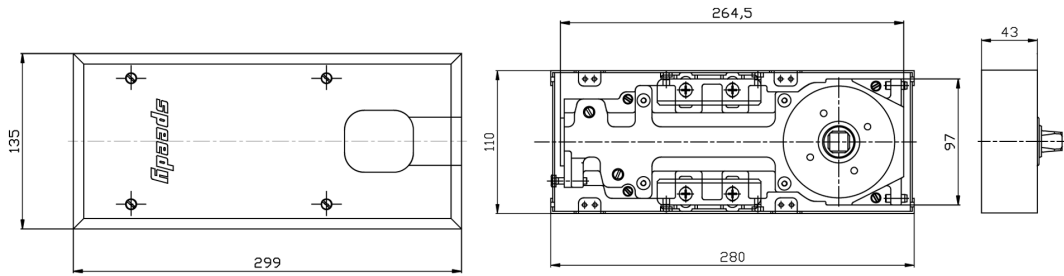

● FERMO COSTANTE
Costant hold-open
Retención constante

● BACK-STOP A 120°
BACK-STOP 120°
BACK-STOP A 120°

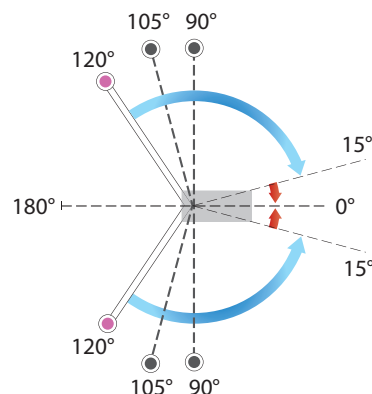



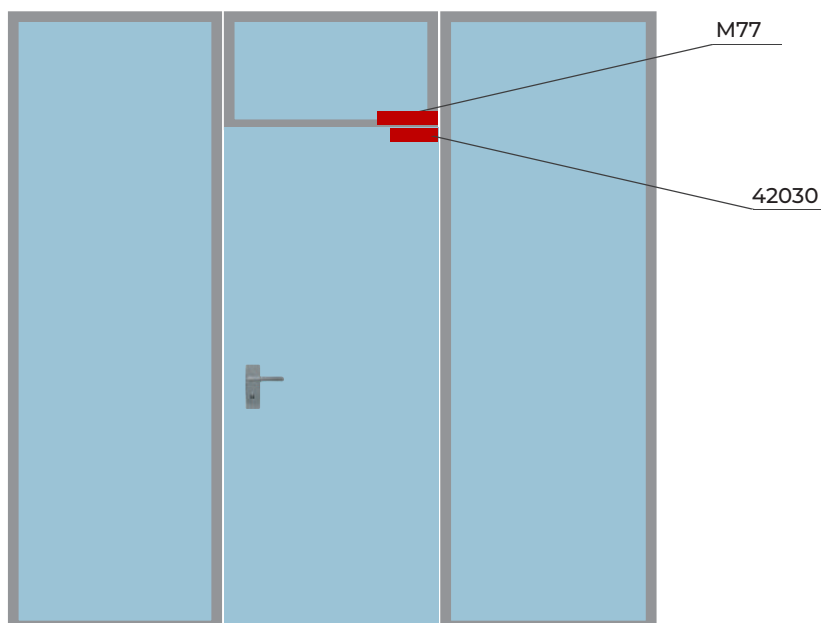

 Larghezza max dell'anta
 Max door width
 Ancho máximo de la puerta
 1000 mm
 39-3/8"

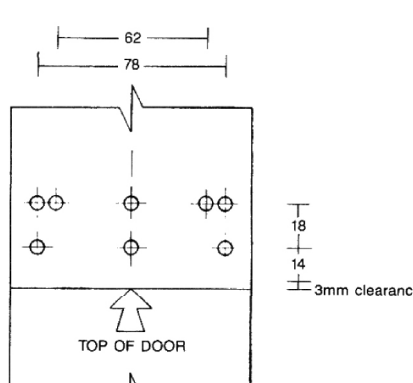
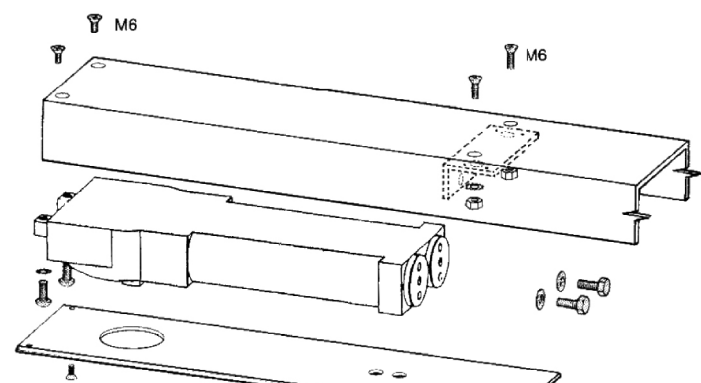
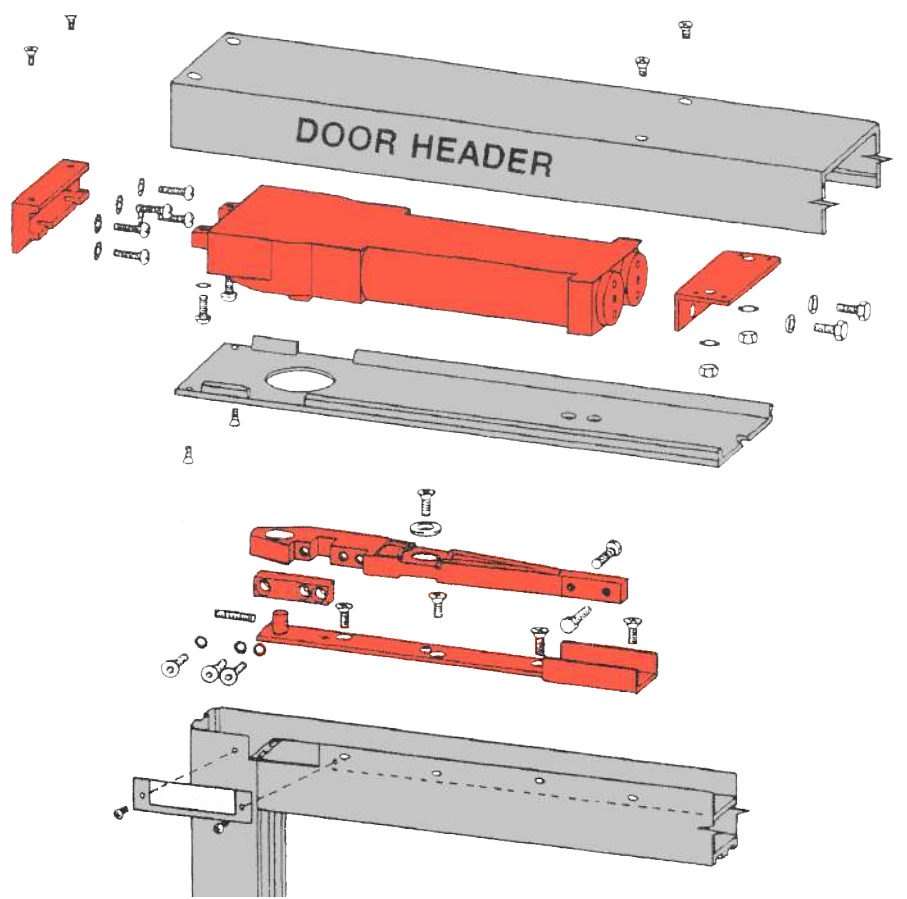
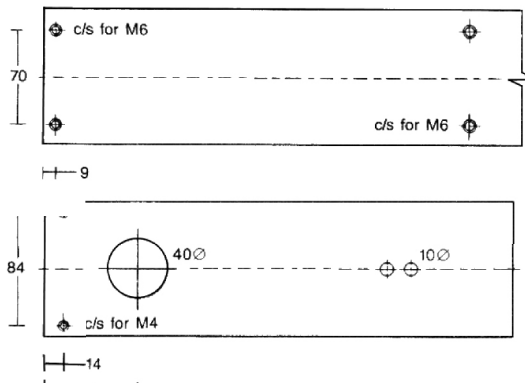
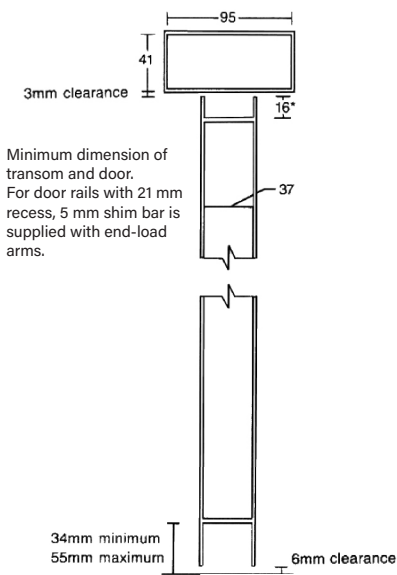
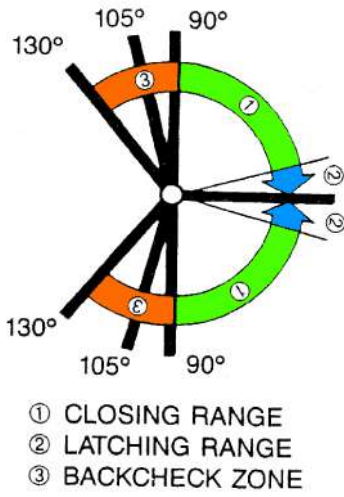

SPEED ADJUSTMENT

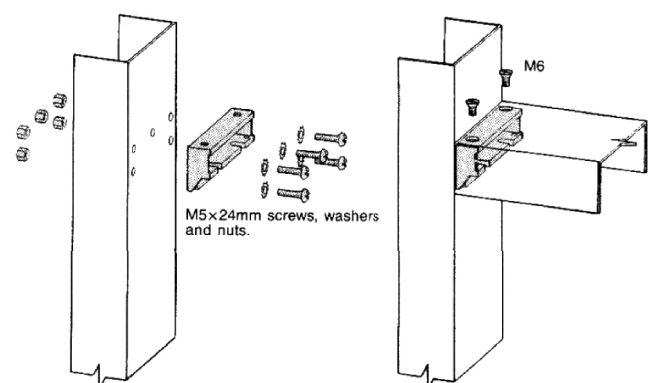

Select fixing holes most suitable for section and drill clearance size for M5 screws.



42030

Cerniera superiore con predisposizione per chiudiporta RTS
Upper hinge for overhead concealed closer
Bisagra superior para cierrapuerta RTS

speedy

! Opzionale | Optional | Opcional
Non incluso in M77
Not included in M77
No incluido en M77

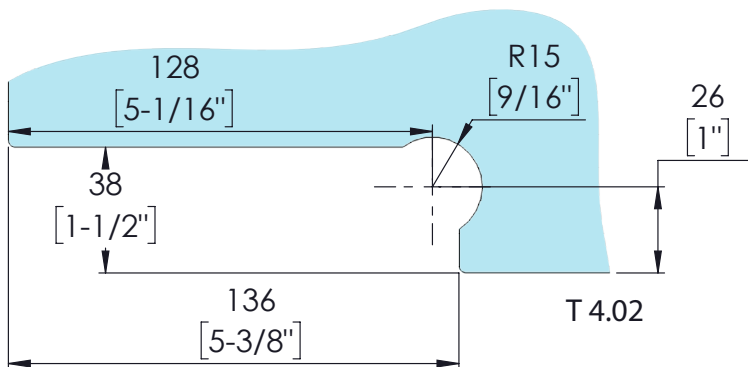
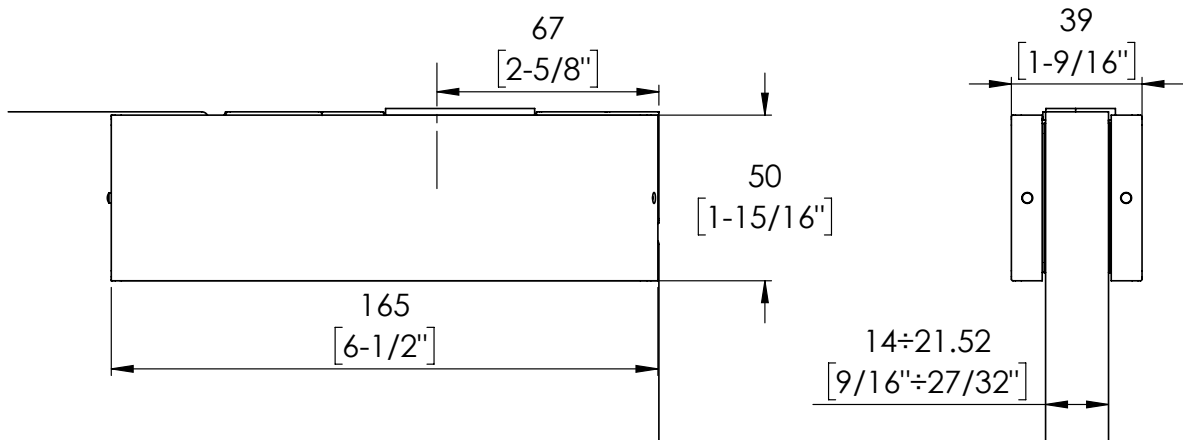
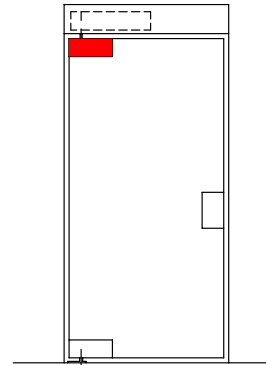
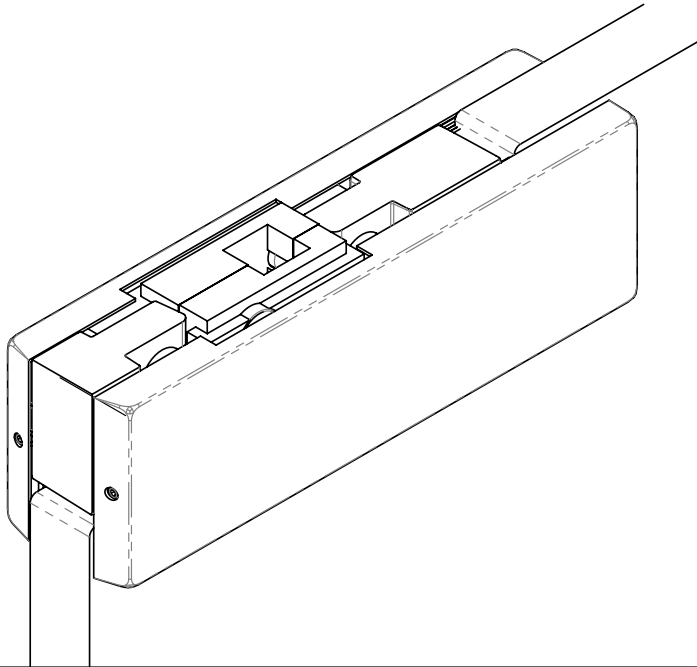

Teste di perno intercambiabili

Interchangeable spindle heads | Pernios intercambiables

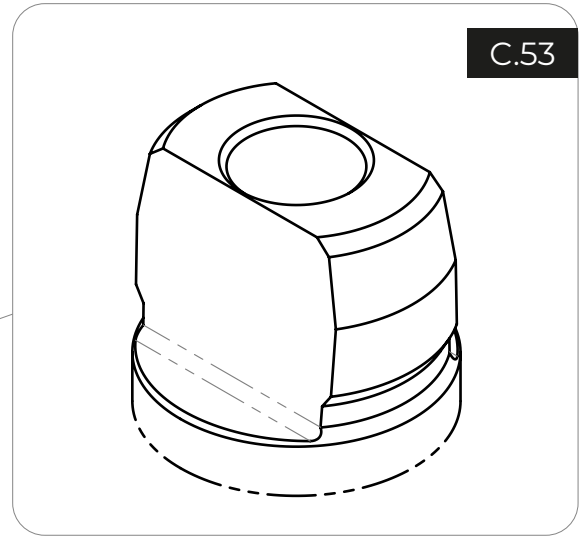
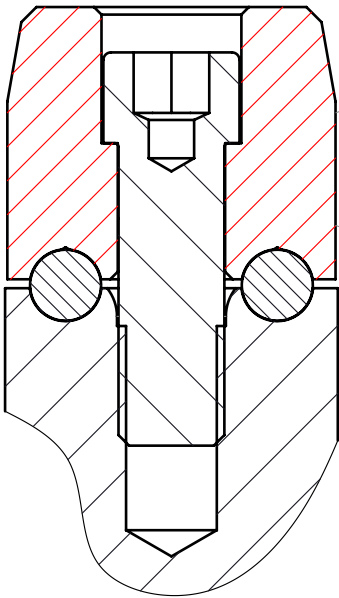

Lunghezza prolunga
Extension length
Longitud extensión

mm	inch
2,5	3/32
5	13/64
8	5/16
10	25/64
12	15/32
15	19/32
20	25/32
25	63/64
30	1" 3/16

Accessori

Accessories | Accesorios

30101

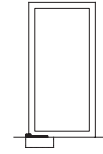
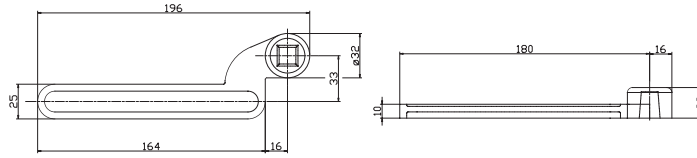
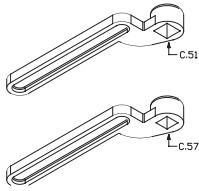

Peso max della porta Max door weight Peso máximo de la puerta	100 Kg	Larghezza max della porta Max door width Ancho máximo de la puerta	1100 mm
Calibri disponibili Available spindles Levas disponibles	51-57	Peso medio Average item weight Peso medio del articulo	0,35 Kg

Note / Notes / Notas: Corpo in ottone, disponibile in finiture ottone grezzo o cromato. Utilizzare con 30200 / Body in brass, rough or chrome plated brass finishes available. Use with 30200/ Cuerpo en latón, disponible en acabados latón bruto o cromado. Acoplar con 30200.

30102

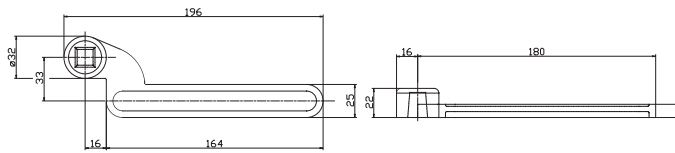
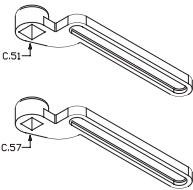

Peso max della porta Max door weight Peso máximo de la puerta	100 Kg	Larghezza max della porta Max door width Ancho máximo de la puerta	1100 mm
Calibri disponibili Available spindles Levas disponibles	51-57	Peso medio Average item weight Peso medio del articulo	0,35 Kg

Note / Notes / Notas: Corpo in ottone, disponibile in finiture ottone grezzo o cromato. Utilizzare con 30200 / Body in brass, rough or chrome plated brass finishes available. Use with 30200/ Cuerpo en latón, disponible en acabados latón bruto o cromado. Acoplar con 30200.

30200

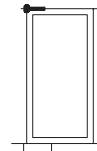
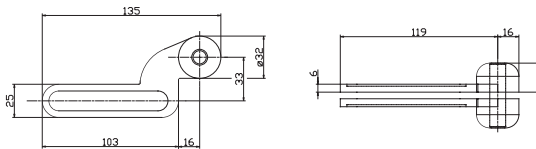
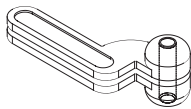

Peso max della porta Max door weight Peso máximo de la puerta	100 Kg	Larghezza max della porta Max door width Ancho máximo de la puerta	1100 mm
Calibri disponibili Available spindles Levas disponibles		Peso medio Average item weight Peso medio del articulo	0,57 Kg

Note / Notes / Notas: Corpo in ottone, disponibile in finiture ottone grezzo o cromato. Utilizzare con 30101 o 30102 / Body in brass, rough or chrome plated brass finishes available. Use with 30101 or 30102/ Cuerpo en latón, disponible en acabados latón bruto o cromado. Acoplar con 30101 o 30102

Accessori

Accessories | Accesorios



30610				
Peso max della porta Max door weight Peso máximo de la puerta		100 Kg	Larghezza max della porta Max door width Ancho máximo de la puerta	1100 mm
Calibri disponibili Available spindles Levas disponibles		51-53-57	Peso medio Average item weight Peso medio del artículo	0,31 Kg
<p>Note / Notes / Notas: Body in brass, rough or chrome plated brass finishes available. Use with 32400/ Cuerpo en latón, disponible en acabados latón bruto o cromado. Acoplar con 32400</p>				

30800				
Peso max della porta Max door weight Peso máximo de la puerta		100 Kg	Larghezza max della porta Max door width Ancho máximo de la puerta	1100 mm
Calibri disponibili Available spindles Levas disponibles		53-57	Peso medio Average item weight Peso medio del artículo	0,12 Kg
<p>Note / Notes / Notas: Corpo in alluminio, disponibile in finitura verniciato nero. Utilizzare con 32400 / Body in aluminium, black painted finishes available. Use with 32400/ Cuerpo en aluminio, disponible en acabado pintado negro. Acoplar con 32400</p>				

31000				
Peso max della porta Max door weight Peso máximo de la puerta		200 Kg	Larghezza max della porta Max door width Ancho máximo de la puerta	1200 mm
Calibri disponibili Available spindles Levas disponibles		53	Peso medio Average item weight Peso medio del artículo	0,31 Kg
<p>Note / Notes / Notas: Corpo in acciaio zincato, disponibile in larghezza lunghezza e foratura a disegno. Utilizzare con 32400 / Body in zinc plated steel. Available also on bespoke length, width, drilling. Use with 32400/ Cuerpo en acero zincado, disponible con ancho, largo y muescas según dibujo. Acoplar con 32400</p>				

Accessori

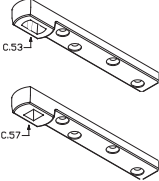
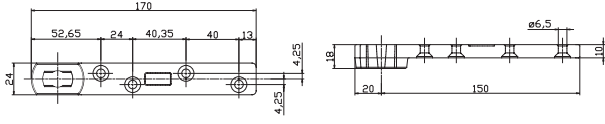
Accessories | Accesorios

30400			
			
Peso max della porta Max door weight Peso máximo de la puerta	100 Kg	Larghezza max della porta Max door width Ancho máximo de la puerta	1100 mm
Calibri disponibili Available spindles Levas disponibles	53-57	Peso medio Average item weight Peso medio del articulo	0,3 Kg
Note / Notes / Notas: Corpo in acciaio zincato. Utilizzare con 32400/ Body in zinc plated steel. Use with 32400/ Cuerpo en acero zincado. Acoplar con 32400			

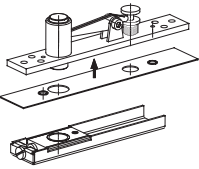
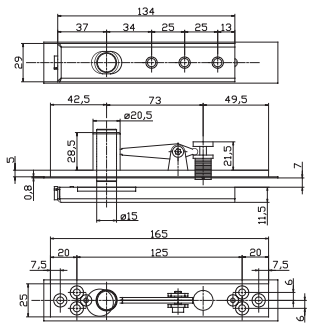
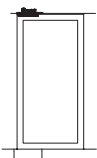
32400			
			
Peso max della porta Max door weight Peso máximo de la puerta	100 Kg	Larghezza max della porta Max door width Ancho máximo de la puerta	1100 mm
Calibri disponibili Available spindles Levas disponibles		Peso medio Average item weight Peso medio del articulo	0,39 Kg
Note / Notes / Notas: Copertina in acciaio inox satinato/ Cover in satin stainless steel / Tapa en acero inoxidable satinado			



PSB g 43606/MPA 1997



ETL ANSI A156.4
Report 4671251960



EN 1154 Test Report



UKAS BS 467 part 22:
1967 TRADA FR 1542B 1991



ETL ANSI A156.4
Report 4671251960



